



Installation and User Manual High-efficiency standing gas boiler

Gas 320 Ace - Gas 620 Ace

HMI T-control

SCB-01

SCB-02

Dear Customer,

Thank you very much for buying this appliance.

Please read through the manual carefully before using the product, and keep it in a safe place for later reference. In order to ensure continued safe and efficient operation we recommend that the product is serviced regularly. Our service and customer service organisation can assist with this.

We hope you enjoy years of problem-free operation with the product.

Contents

1	Safety	6
1.1	General safety instructions	6
1.1.1	For the installer	6
1.1.2	For the end user	7
1.2	Recommendations	8
1.3	Liabilities	10
1.3.1	Manufacturer's liability	10
1.3.2	Installer's liability	10
1.3.3	User's liability	10
2	About this manual	12
2.1	General	12
2.2	Additional documentation	12
2.3	Symbols used in the manual	12
3	Description of the product	13
3.1	Boiler types	13
3.2	Main components	13
3.3	Introduction to the e-Smart controls platform	15
4	Before installation	16
4.1	Installation regulations	16
4.2	Location requirements	16
4.3	Requirements for water connections	17
4.3.1	Requirements for the central heating connections	17
4.3.2	Requirements for the condensate drain	17
4.3.3	Flushing the system	17
4.4	Requirements for the gas connection	17
4.5	Requirements on the flue gas discharge system	18
4.5.1	Classification	18
4.5.2	Material	20
4.5.3	Dimensions of flue gas outlet pipe	21
4.5.4	Length of the flue and air supply pipes	21
4.5.5	Additional guidelines	23
4.6	Requirements for the electrical connections	24
4.7	Water quality and water treatment	24
4.8	Installation examples	24
4.8.1	How to use the installation examples	24
4.8.2	How to find the desired installation example	26
4.8.3	Symbols used	29
4.8.4	SCB-02 Installation example 01-01-02-10-00-00-00	30
4.8.5	SCB-02 Installation example 01-01-01-10-00-00-00	31
5	Installation	33
5.1	Positioning the boiler	33
5.2	Rotating the control box	33
5.3	Connecting the heating circuit	35
5.4	Connecting the condensate discharge pipe	35
5.5	Connecting the gas pipe	35
5.6	Connecting the air inlet and flue gas outlet	36
5.7	Electrical connections	36
5.7.1	PCB locations	36
5.7.2	The CB-01 connection PCB	37
5.7.3	The SCB-01 expansion PCB	39
5.7.4	The SCB-02 expansion PCB	40
5.7.5	Connecting the power cable	43
5.7.6	Cable routing in the control box front part	44
6	Preparation of commissioning	45
6.1	Checklist before commissioning	45
6.1.1	Filling the installation	45
6.1.2	Filling the siphon	45
6.1.3	Preparing the gas circuit	45
6.2	Control panel description	46

6.2.1	Control panel components	46
6.2.2	Description of the home screen	46
6.2.3	Description of the main menu	46
6.2.4	Meaning of the icons in the display	47
7	Commissioning	49
7.1	Commissioning procedure	49
7.2	Gas settings	49
7.2.1	Factory setting	49
7.2.2	Adjusting to a different gas type	50
7.2.3	Fan speeds for BREEAM compliance	50
7.2.4	Checking and setting the gas/air ratio	51
7.3	Final instructions	55
7.3.1	Saving the commissioning settings	55
8	Settings	57
8.1	Introduction to parameter codes	57
8.2	Accessing the installer level	57
8.2.1	Configuring the installation at installer level	57
8.2.2	Establishing a Bluetooth connection	58
8.3	List of parameters	58
8.3.1	CU-GH13 control unit settings - Gas 320 Ace	58
8.3.2	CU-GH13 control unit settings - Gas 620 Ace	65
9	Maintenance	72
9.1	Maintenance regulations	72
9.2	Opening the boiler	72
9.3	Disposal and recycling	73
10	Troubleshooting	74
10.1	Error codes	74
10.1.1	Display of error codes	74
10.1.2	Warning	75
10.1.3	Blocking	76
10.1.4	Locking	79
10.2	Error history	83
10.2.1	Reading out and clearing the error memory	83
11	User instructions	84
11.1	Start-up	84
11.2	Accessing the user level menus	84
11.3	Heating circuit configuration	84
11.4	Changing the display settings	85
11.5	Timer program to control the room temperature	85
11.5.1	Creating a timer program	85
11.6	Reading the installer's name and phone number	86
11.7	Shut-down	86
11.8	Frost protection	86
11.9	Cleaning the casing	87
12	Technical specifications	88
12.1	Homologations	88
12.1.1	Certifications	88
12.1.2	Directives	88
12.1.3	Bluetooth® wireless technology	88
12.1.4	Factory test	88
12.2	Electrical diagram	89
12.3	Dimensions and connections Gas 320 Ace	90
12.4	Dimensions and connections Gas 620 Ace	91
12.5	Hydraulic resistance	92
12.6	Gas 320 Ace technical data	92
12.7	Gas 620 Ace technical data	95
12.8	BLE Smart Antenna technical data	98
13	Appendix	99
13.1	ErP information	99

13.1.1 Product fiche 99

13.2 EC declaration of conformity 99

13.2.1 Declaration of conformity for wireless devices 99

1 Safety

1.1 General safety instructions

1.1.1 For the installer



Danger

If you smell gas:

1. Do not use naked flames, do not smoke and do not operate electrical contacts or switches (doorbell, lighting, motor, lift etc.).
2. Shut off the gas supply.
3. Open the windows.
4. Trace possible leaks and seal them off immediately.
5. If the leak is upstream of the gas meter, notify the gas company.



Danger

If you smell flue gases:

1. Switch the boiler off.
2. Open the windows.
3. Trace possible leaks and seal them off immediately.



Caution

After maintenance or repair work, check the entire heating installation to ensure that there are no leaks.

1.1.2 For the end user



Danger

If you smell gas:

1. Do not use naked flames, do not smoke and do not operate electrical contacts or switches (doorbell, lighting, motor, lift etc.).
2. Shut off the gas supply.
3. Open the windows.
4. Report any leaks immediately.
5. Evacuate the property.
6. Contact a qualified installer.



Danger

If you smell flue gases:

1. Switch the boiler off.
2. Open the windows.
3. Report any leaks immediately.
4. Evacuate the property.
5. Contact a qualified installer.



Warning

Do not touch the flue gas pipes. Depending on the boiler settings, the temperature of the flue gas pipes can rise to over 60°C.



Warning

Do not touch radiators for long periods. Depending on the boiler settings, the temperature of the radiators can rise to over 60°C.



Warning

Be careful when using the domestic hot water. Depending on the boiler settings, the temperature of domestic hot water can rise to over 65°C.



Warning

The use of the boiler and the installation by you as the end-user must be limited to the operations described in this manual. All other actions may only be undertaken by a qualified fitter/engineer.



Warning

The condensate drain must not be modified or sealed. If a condensate neutralisation system is used, the system must be cleaned regularly in accordance with the instructions provided by the manufacturer.



Caution

Ensure that the boiler is regularly serviced. Contact a qualified installer or arrange a maintenance contract for the servicing of the boiler.



Caution

Only genuine spare parts may be used.



Important

Regularly check for the presence of water and pressure in the heating installation.

1.2 Recommendations



Danger

This appliance can be used by children aged eight and above and people with a physical, sensory or mental disability, or with a lack of experience and knowledge, provided they are supervised and instructed in how to use the appliance in a safe manner and understand the associated dangers. Children must not be allowed to play with the appliance. Cleaning and user maintenance should not be carried out by children without adult supervision.



Warning

Installation and maintenance of the boiler must be carried out by a qualified installer in accordance with local and national regulations.



Warning

The installation and maintenance of the boiler must be undertaken by a qualified installer in accordance with the information in the supplied manual, doing otherwise may result in dangerous situations and/or bodily injury.



Warning

Removal and disposal of the boiler must be carried out by a qualified installer in accordance with local and national regulations.



Warning

If the mains lead is damaged, it must be replaced by the original manufacturer, the manufacturer's dealer or another suitably skilled person to prevent hazardous situations from arising.

**Warning**

Always disconnect the mains supply and close the main gas tap when working on the boiler.

**Warning**

Check the entire system for leaks after maintenance and servicing work.

**Danger**

For safety reasons, we recommend fitting smoke alarms at suitable places and a CO detector near the appliance.

**Caution**

- Make sure the boiler can be reached at all times.
- The boiler must be installed in a frost-free area.
- If the power cord is permanently connected, you must always install a main bipolar switch with an opening gap of at least 3 mm (BS EN 60335-1).
- Drain the boiler and central heating system if you are not going to use your home for a long time and there is a chance of frost.
- The frost protection does not work if the boiler is out of operation.
- The boiler protection only protects the boiler, not the system.
- Check the water pressure in the system regularly. If the water pressure is lower than 0.8 bar, the system must be topped up (recommended water pressure between 1.5 and 2.0 bar).

**Important**

Keep this document near to the boiler.

**Important**

Only remove the casing for maintenance and repair operations. Refit all panels when maintenance work and servicing are complete.

**Important**

Instruction and warning labels must never be removed or covered and must be clearly legible throughout the entire service life of the boiler. Damaged or illegible instructions and warning stickers must be replaced immediately.

**Important**

Modifications to the boiler require the written approval of **Remeha**.

1.3 Liabilities

1.3.1 Manufacturer's liability

Our products are manufactured in compliance with the requirements of the various Directives applicable. They are therefore delivered with the CE marking and any documents necessary. In the interests of the quality of our products, we strive constantly to improve them. We therefore reserve the right to modify the specifications given in this document.

Our liability as manufacturer may not be invoked in the following cases:

- Failure to abide by the instructions on installing and maintaining the appliance.
- Failure to abide by the instructions on using the appliance.
- Faulty or insufficient maintenance of the appliance.

1.3.2 Installer's liability

The installer is responsible for the installation and initial commissioning of the appliance. The installer must observe the following instructions:

- Read and follow the instructions given in the manuals provided with the appliance.
- Install the appliance in compliance with prevailing legislation and standards.
- Carry out initial commissioning and any checks necessary.
- Explain the installation to the user.
- If maintenance is necessary, warn the user of the obligation to check the appliance and keep it in good working order.
- Give all the instruction manuals to the user.

1.3.3 User's liability

To guarantee optimum operation of the system, you must abide by the following instructions:

- Read and follow the instructions given in the manuals provided with the appliance.
- Call on a qualified professional to carry out installation and initial commissioning.

- Get your installer to explain your installation to you.
- Have the required inspections and maintenance carried out by a qualified installer.
- Keep the instruction manuals in good condition close to the appliance.

2 About this manual

2.1 General

This manual is intended for the installer and end user of a Gas 320/620 Ace boiler.

2.2 Additional documentation

The following documentation is available in addition to this manual:

- Product information
- Service manual
- Water quality instructions

2.3 Symbols used in the manual

This manual contains special instructions, marked with specific symbols. Please pay extra attention when these symbols are used.

**Danger**

Risk of dangerous situations that may result in serious personal injury.

**Danger of electric shock**

Risk of electric shock that may result in serious personal injury.

**Warning**

Risk of dangerous situations that may result in minor personal injury.

**Caution**

Risk of material damage.

**Important**

Please note: important information.

**See**

Reference to other manuals or pages in this manual.

3 Description of the product

3.1 Boiler types

The following boiler types are available:

Tab.1 Boiler types

Name	Output ⁽¹⁾	Heat exchanger size
Gas 320 Ace 285	279 kW	5 sections
Gas 320 Ace 355	350 kW	6 sections
Gas 320 Ace 430	425 kW	7 sections
Gas 320 Ace 500	497 kW	8 sections
Gas 320 Ace 575	574 kW	9 sections
Gas 320 Ace 650	652 kW	10 sections
Gas 620 Ace 570	558 kW	2 x 5 sections
Gas 620 Ace 710	701 kW	2 x 6 sections
Gas 620 Ace 860	849 kW	2 x 7 sections
Gas 620 Ace 1000	994 kW	2 x 8 sections
Gas 620 Ace 1150	1147 kW	2 x 9 sections
Gas 620 Ace 1300	1303 kW	2 x 10 sections

(1) Nominal output $P_{nc} 50/30$ °C

3.2 Main components

Fig.1 General - front

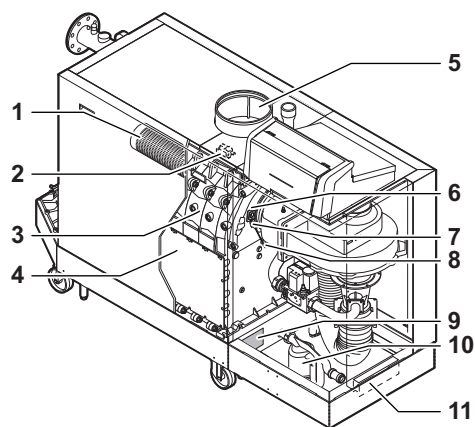

- 1 Burner
- 2 Ignition / ionisation transformer
- 3 Heat exchanger
- 4 Inspection hatch
- 5 Air inlet connection
- 6 Flame inspection glass
- 7 Ignition / ionisation electrode
- 8 Heat exchanger temperature sensor
- 9 Data plate
- 10 Siphon
- 11 Document holder

Fig.2 Gas 320 Ace - back

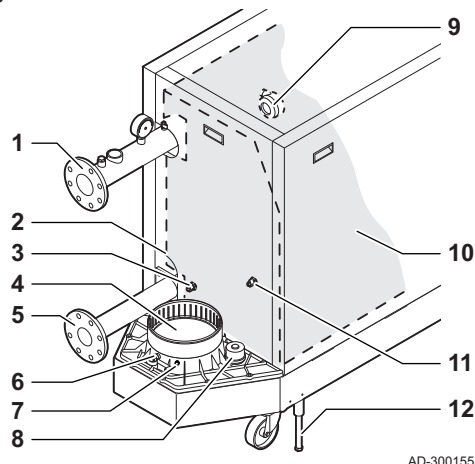

- 1 Flow connection
- 2 Second return connection
- 3 Return temperature sensor (when no second return is fitted)
- 4 Flue gas outlet connection
- 5 Return connection
- 6 Flue gas measuring point
- 7 Flue gas temperature sensor
- 8 Condensate collector cap
- 9 Air pressure differential switch
- 10 Heat exchanger insulation kit (optional)
- 11 Return temperature sensor (when a second return is fitted)
- 12 Levelling foot

Fig.3 Gas 620 Ace - back

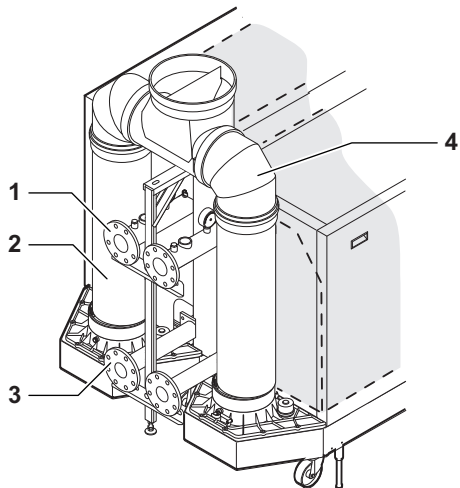

AD-3001554-01

- 1 Flow connection
- 2 Flue gas outlet
- 3 Return connection
- 4 Flue gas collector

Fig.4 Gas - air unit

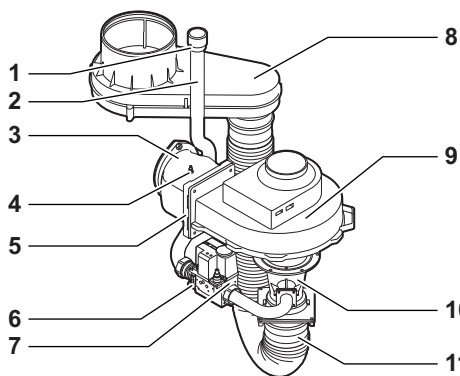

AD-3001555-01

- 1 Gas pressure measuring point
- 2 Gas supply tube
- 3 Gas - air connection piece
- 4 Pressure measurement point
- 5 Non-return valve
- 6 Gas filter
- 7 Gas valve
- 8 Air box
- 9 Fan
- 10 Venturi
- 11 Air supply hose

Fig.5 Control box

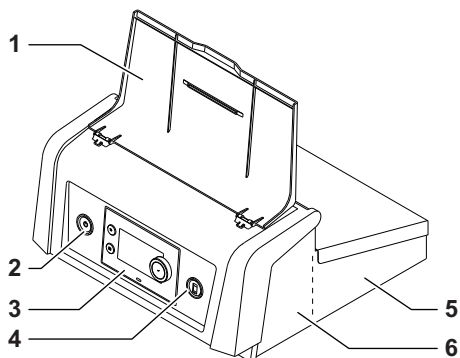

AD-3001556-01

- 1 Display cover
- 2 Power button
- 3 Control panel
- 4 Service connector
- 5 Control box rear part - for expansion PCBs with wire connections
- 6 Control box front part - for the control unit and connectivity expansion PCBs

Fig.6 Flow pipe

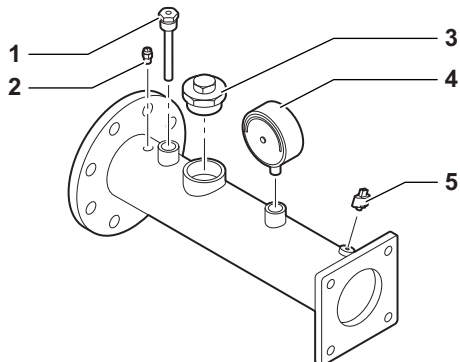

AD-3001557-01

- 1 Temperature sensor (external control) immersion tube (1/2")
- 2 Air vent (1/8")
- 3 Safety valve connection (1 1/2")
- 4 Pressure gauge (1/2")
- 5 Flow temperature sensor (M6)

3.3 Introduction to the e-Smart controls platform

The Gas 320/620 Ace boiler is equipped with the e-Smart controls platform. This is a modular system, and offers compatibility and connectivity between all products that make use of the same platform.

Fig.7 Generic example

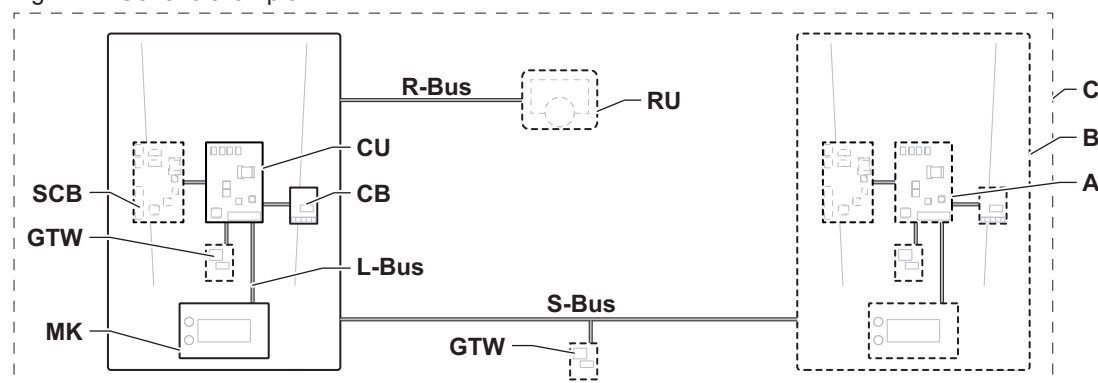

AD-3001366-02

Tab.2 Components in the example

Item	Description	Function
CU	Control Unit: Control unit	The control unit handles all basic functionality of the appliance.
CB	Connection Board: Connection PCB	The connection PCB provides easy access to all connectors of the control unit.
SCB	Smart Control Board: Expansion PCB	An expansion PCB provides extra functionality, like an internal calorifier or multiple zones.
GTW	Gateway: Conversion PCB	A gateway can be fitted to an appliance or system, to provide one of the following: <ul style="list-style-type: none"> • Extra (wireless) connectivity • Service connections • Communication with other platforms
MK	Control panel: Control panel and display	The control panel is the user interface to the appliance.
RU	Room Unit: Room unit (for example, a thermostat)	A room unit measures the temperature in a reference room.
L-Bus	Local Bus: Connection between devices	The local bus provides communication between devices.
S-Bus	System Bus: Connection between appliances	The system bus provides communication between appliances.
R-Bus	Room unit Bus: Connection to a room unit	The room unit bus provides communication to a room unit.
A	Device	A device is a PCB, control panel or a room unit.
B	Appliance	An appliance is a set of devices connected via the same L-Bus
C	System	A system is a set of appliances connected via the same S-Bus

Tab.3 Specific devices delivered with the Gas 320/620 Ace boiler

Name visible in display	Software version	Description	Function
CU-GH13	1.1	Control unit CU-GH13	The CU-GH13 control unit handles all basic functionality of the Gas 320/620 Ace boiler.
MK3	1.29	Control panel HMI T-control	The HMI T-control is the user interface to the Gas 320/620 Ace boiler.
SCB-01	1.2	Expansion PCB SCB-01	The SCB-01 provides a 0-10 V connection for a PWM system pump and two potential-free contacts for status notification.
SCB-02	1.3	Expansion PCB SCB-02	The SCB-02 provides functionality for a DHW and central heating zone, a 0-10 V connection for a PWM system pump and two potential-free contacts for status notification.
GTW-Bluetooth	-	Gateway BLE Smart Antenna	The BLE Smart Antenna provides functionality to connect the boiler to an app via Bluetooth.

4 Before installation

4.1 Installation regulations



Important

The boiler must be installed by a qualified installer in accordance with local and national regulations.

4.2 Location requirements



Danger

It is forbidden to store, even temporarily, combustible products and substances in or near the boiler.



Caution

- The boiler must be installed in a frost-free area.
- An earthed electrical connection must be available close to the boiler.
- A connection to the drain must be present for the condensate drain close to the boiler.

When choosing the best installation location, consider:

- The regulations.
- The required installation space.
- The required space around the boiler for good access and to facilitate maintenance.
- The permitted position of the flue gas outlet and/or air supply opening.

Fig.8 Location requirements

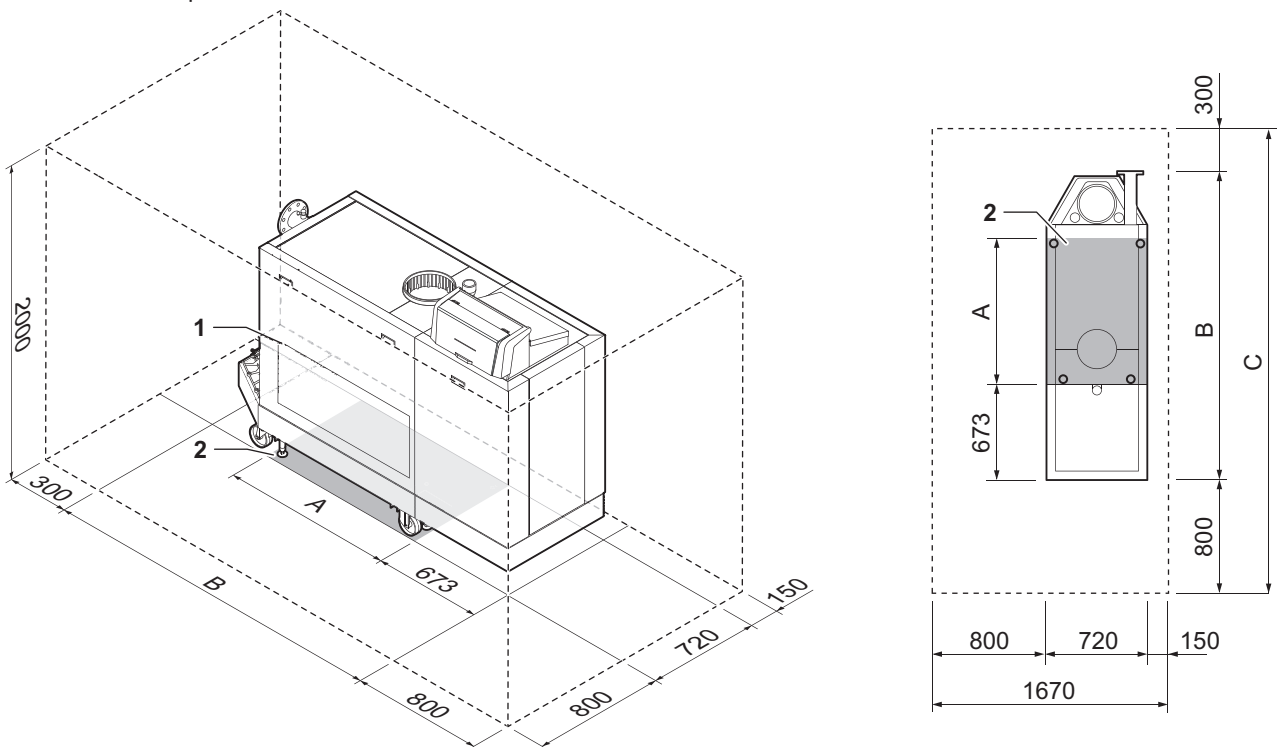

- 1 Heat exchanger inspection hatch location
- 2 Support surface
- A Support surface length (see table)

- B Boiler length (see table)
- C Total length required (see table)

AD-3001441-01

Tab.4 Dimensions A / B / C (mm)

Gas 320 Ace	Gas 620 Ace	A (mm)	B (mm)	C (mm)
285	570	723	1862	2962
355	710	723	1862	2962

Gas 320 Ace	Gas 620 Ace	A (mm)	B (mm)	C (mm)
430	860	723	1862	2962
500	1000	1032	2172	3272
575	1150	1032	2172	3272
650	1300	1032	2172	3272

4.3 Requirements for water connections

- Before installation, check that the connections meet the set requirements.
- Carry out any welding work required at a safe distance from the boiler.
- If using synthetic pipes, follow the manufacturer's instructions.

4.3.1 Requirements for the central heating connections

- We recommend installing a central heating filter in the return pipe to prevent clogging of boiler components.

4.3.2 Requirements for the condensate drain

- The drain pipe must be Ø 32 mm or larger, terminating in the drain.
- Use only plastic material for the discharge pipe due to the acidity (pH 2 to 5) of the condensate.
- Fit a watertrap or siphon in the drain pipe.
- The drain pipe must slope down at least 30 mm per metre, the maximum horizontal length is 5 metres.
- Do not make a fixed connection in order to prevent an overpressure in the siphon.

4.3.3 Flushing the system

The installation must be cleaned and flushed in accordance with BS 7593 (2019) and BSRIA BG 33/2014.

Before a new boiler can be connected to a system, the entire system must be thoroughly cleaned by flushing it. The flushing will remove residue from the installation process (weld slag, fixing products etc.) and accumulations of dirt (silt, mud etc.)

Important

- Flush the heating system with a volume of water equivalent to at least three times the volume of the system.
- Flush the domestic hot water pipes with at least 20 times the volume of the pipes.

Important

Due to the presence of an aluminium heat exchanger, suitable chemicals and the correct use of these chemicals should be discussed with specialist water treatment companies.

4.4 Requirements for the gas connection

- Carry out any welding work required at a safe distance from the boiler.
- Before installing, check that the gas meter has sufficient capacity. Take into account the consumption of all appliances. Notify the local energy company if the gas meter has insufficient capacity.
- We recommend installing a gas filter to prevent clogging of the gas valve unit.

4.5 Requirements on the flue gas discharge system

4.5.1 Classification

i Important

- The installer is responsible ensuring that the right type of flue gas outlet system is used and that the diameter and length are correct.
- Always use connection materials, roof terminal and/or outside wall terminal supplied by the same manufacturer. Consult the manufacturer for compatibility details.
- The use of flue gas outlet systems from other manufacturers is allowed in addition to the recommended manufacturers listed in this manual. Use is only allowed when all our requirements are met and the description of flue gas connection C₆₃ is respected.

Tab.5 Type of flue gas connection: B₂₃ - B_{23P}

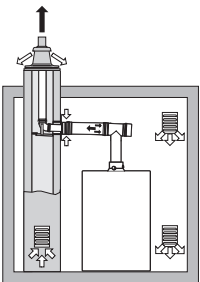
Principle	Description	Recommended manufacturers ⁽¹⁾
 <p>AD-3001055-01</p>	<p>Room-ventilated version</p> <ul style="list-style-type: none"> • Without down-draught diverter. • Flue gas discharge via the roof. • Air from the installation area. • The air supply opening of the boiler must stay open. • The installation area must be vented to ensure sufficient air supply. The vents must not be obstructed or shut off. • The IP rating of the boiler is lowered to IP20. 	<p>Connection material and roof terminal:</p> <ul style="list-style-type: none"> • Alukan • Cox Geelen • Muelink & Grol
<p>(1) The material must also satisfy the material property requirements from the relevant chapter.</p>		

Tab.6 Type of flue gas connection: C₃₃

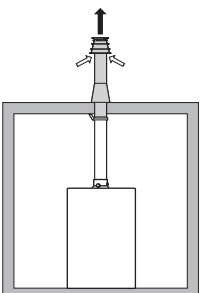
Principle	Description	Recommended manufacturers ⁽¹⁾
 <p>AD-3001057-01</p>	<p>Room-sealed version</p> <ul style="list-style-type: none"> • Flue gas discharge via the roof. • Air supply opening is in the same pressure zone as the discharge (e.g. a concentric roof terminal). 	<p>Roof terminal and connection material</p> <ul style="list-style-type: none"> • Remeha, combined with connection material from Muelink & Grol • Remeha 350/350, in combination with connection material from Alukan (Only for Remeha Gas 620 Ace) • Cox Geelen • Muelink & Grol
<p>(1) The material must also satisfy the material property requirements from the relevant chapter.</p>		

Tab.7 Type of flue gas connection: C₅₃

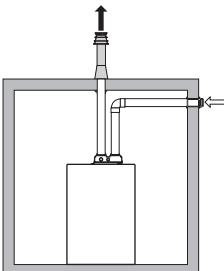
Principle	Description	Recommended manufacturers ⁽¹⁾
 <p>AD-3001058-02</p>	<p>Connection in different pressure zones</p> <ul style="list-style-type: none"> • Closed unit. • Separate air supply duct. • Separate flue gas discharge duct. • Discharging into various pressure areas. • The air supply and the flue gas outlet must not be placed on opposite walls. 	<p>Connection material and roof terminal:</p> <ul style="list-style-type: none"> • Alukan • Cox Geelen • Muelink & Grol
<p>(1) The material must also satisfy the material property requirements from the relevant chapter.</p>		

Tab.8 Type of flue gas connection: C₆₃

Principle	Description	Recommended manufacturers ⁽¹⁾
	<p>This type of unit is supplied by us without an air supply system and flue gas system.</p> <p>When selecting the material, please note the following:</p> <ul style="list-style-type: none"> • Condensed water must flow back to the boiler. • The material must be resistant to the flue gas temperature of this boiler. • Maximum permissible recirculation of 10%. • The air supply and the flue gas outlet must not be placed on opposite walls. • Minimum permitted pressure difference between the air supply and the flue gas outlet is -200 Pa (including -100 Pa wind pressure). 	<p>Use is only allowed when all our requirements are met and the description of this type of flue gas connection is respected.</p>
<p>(1) The material must also satisfy the material property requirements from the relevant chapter.</p>		

Tab.9 Type of flue gas connection: C₉₃

Principle ⁽¹⁾	Description	Recommended manufacturers ⁽²⁾
 <p>AD-3001059-01</p>	<p>Room-sealed version</p> <ul style="list-style-type: none"> • Air supply and flue gas discharge duct in shaft or ducted: <ul style="list-style-type: none"> - Concentric. - Air supply from existing duct. - Flue gas discharge via the roof. - Inlet opening for the air supply is in the same pressure zone as the discharge. 	<p>Connection material and roof terminal:</p> <ul style="list-style-type: none"> • Alukan • Cox Geelen • Muelink & Grol
<p>(1) See table for shaft or duct requirements.</p> <p>(2) The material must also satisfy the material property requirements from the relevant chapter.</p>		

Fig.9 Minimum dimensions of shaft or duct C₉₃



AD-3000330-03

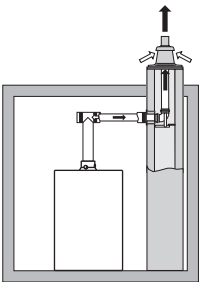
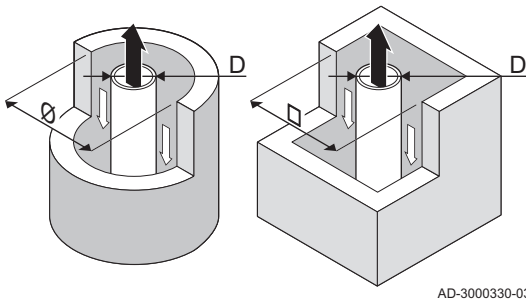

Important

The shaft must comply with the air density requirements of the local regulations.



Important

- Always clean shafts thoroughly when using lining pipes and/or an air supply connection.
- It must be possible to inspect the lining duct.

4.5.2 Material

Use the string on the flue gas outlet material to check whether it is suitable for use on this appliance.

Fig.10 Sample string

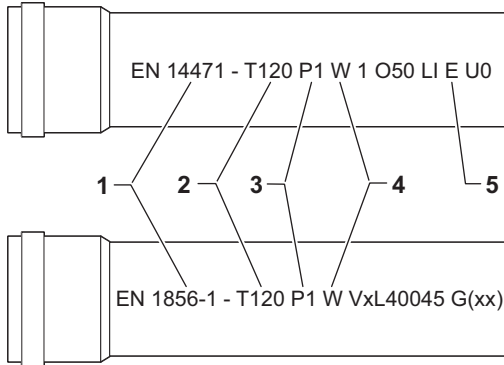

AD-3001120-01

- 1 EN 14471 of EN 1856-1:** The material is CE approved according to this standard. For plastic this is EN 14471, For aluminium and stainless steel this is EN 1856-1.
- 2 T120:** The material has temperature class T120. A higher number is also allowed, but not lower.
- 3 P1:** The material falls into pressure class P1. H1 is also allowed.
- 4 W:** The material is suitable for draining condensation water (W='wet'). D is not allowed (D='dry').
- 5 E:** The material falls into fire resistance class E. Class A to D are also allowed, F is not allowed. Only applicable to plastic.



Warning

- The coupling and connection methods may vary depending on the manufacturer. It is not permitted to combine pipes, coupling and connection methods from different manufacturers. This also applies to roof feed-throughs and common channels.
- The materials used must comply with the prevailing regulations and standards.
- Please contact us to discuss using flexible flue gas outlet material.

Tab.10 Overview of material properties

Version	Flue gas outlet		Air supply	
	Material	Material properties	Material	Material properties
Single-wall, rigid	<ul style="list-style-type: none"> • Plastic⁽¹⁾ • Stainless steel⁽²⁾ • Thick-walled, aluminium⁽²⁾ 	<ul style="list-style-type: none"> • With CE marking • Temperature class T120 or higher • Condensate class W (wet) • Pressure class P1 or H1 • Fire resistance class E or better⁽³⁾ 	<ul style="list-style-type: none"> • Plastic • Stainless steel • Aluminium 	<ul style="list-style-type: none"> • With CE marking • Pressure class P1 or H1 • Fire resistance class E or better⁽³⁾
(1) according to EN 14471 (2) according to EN 1856 (3) according to EN 13501-1				

4.5.3 Dimensions of flue gas outlet pipe



Warning

The pipes connected to the flue gas adapter must satisfy the following dimension requirements.

d_1 External dimensions of flue gas outlet pipe

Tab.11 Dimensions of pipe

	d_1 (min-max)
250 mm	249 - 251 mm
350 mm	349 - 351 mm

Fig.11 Dimensions of open connection

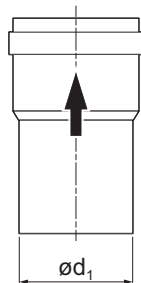

AD-3001094-01

4.5.4 Length of the flue and air supply pipes

The maximum length of the flue and air supply vary per appliance type. Consult the relevant chapter for the correct lengths.

- If a boiler is not compatible with a specific flue system or diameter, it is indicated with "-" in the table.
- When using bends, the maximum flue length (L) must be shortened according to the reduction table.
- Use approved flue reducers for adaptation to another diameter.
- The boiler also supports other flue lengths and diameters than those specified in the tables. Contact us for more information.

■ Room-ventilated system (B₂₃, B_{23P})

With a room-ventilated system, only the flue is connected. The air supply is not connected and will draw the combustion air directly from the installation area.

L Length of the flue to roof terminal

 Flue gas outlet connection

Fig.12 Room-ventilated system Gas 320 Ace



AD-3001561-01

Tab.12 Maximum length (L)

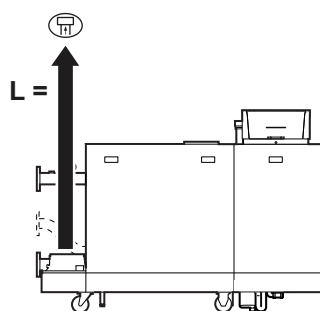
Diameter ⁽¹⁾	250 mm
Gas 320 Ace 285	50 m ⁽¹⁾
Gas 320 Ace 355	50 m ⁽¹⁾
Gas 320 Ace 430	50 m ⁽¹⁾
Gas 320 Ace 500	50 m ⁽¹⁾
Gas 320 Ace 575	50 m ⁽¹⁾
Gas 320 Ace 650	50 m

(1) While maintaining maximum length, additional 5 times 90° or 10 times 45° bends can be used (indicated for each boiler type and diameter).

Fig.13 Room-ventilated system Gas 620 Ace

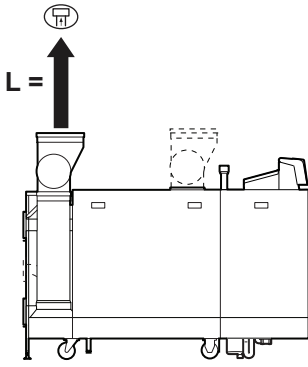

AD-3001564-01

L Length of the flue to roof terminal
 Flue gas outlet connection

Tab.13 Maximum length (L)

Diameter ⁽¹⁾	250 mm	300 mm	350 mm
Gas 620 Ace 570	50 m ⁽¹⁾	50 m ⁽¹⁾	50 m ⁽¹⁾
Gas 620 Ace 710	31 m	50 m ⁽¹⁾	50 m ⁽¹⁾
Gas 620 Ace 860	20 m	50 m ⁽¹⁾	50 m ⁽¹⁾
Gas 620 Ace 1000	11 m	39 m	50 m ⁽¹⁾
Gas 620 Ace 1150	5 m	26 m	50 m
Gas 620 Ace 1300	3 m	19 m	50 m

(1) While maintaining maximum length, additional 5 times 90° or 10 times 45° bends can be used (indicated for each boiler type and diameter).



■ Room-sealed system (C₃₃, C₆₃, C₉₃)

With a room-sealed system, both the flue and the air supply are connected.

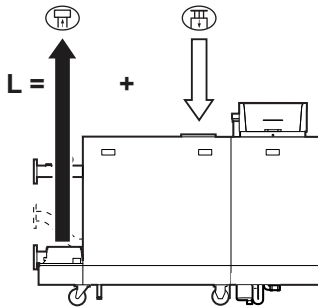
Fig.14 Room-sealed system Gas 320 Ace



AD-3001562-01

L Combined length of the flue and air supply channel to the roof terminal
 Flue gas outlet connection
 Air supply connection

Tab.14 Maximum length (L)



Diameter ⁽¹⁾	250 mm	300 mm
Gas 320 Ace 285	100 m ⁽¹⁾	100 m ⁽¹⁾
Gas 320 Ace 355	100 m ⁽¹⁾	100 m ⁽¹⁾
Gas 320 Ace 430	100 m	100 m ⁽¹⁾
Gas 320 Ace 500	100 m	100 m ⁽¹⁾
Gas 320 Ace 575	68 m	100 m ⁽¹⁾
Gas 320 Ace 650	48 m	100 m ⁽¹⁾

(1) While maintaining maximum length, additional 5 times 90° or 10 times 45° bends can be used (indicated for each boiler type and diameter).

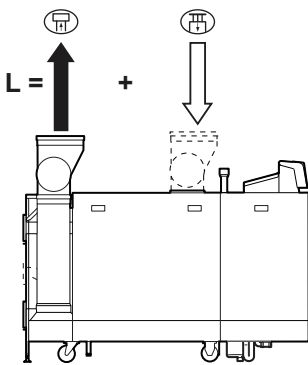
Fig.15 Room-sealed system Gas 620 Ace



AD-3001565-01

L Combined length of the flue and air supply channel to the roof terminal
 Flue gas outlet connection
 Air supply connection

Tab.15 Maximum length (L)

Diameter ⁽¹⁾	300 mm	350 mm	400 mm
Gas 620 Ace 570	100 m ⁽¹⁾	100 m ⁽¹⁾	100 m ⁽¹⁾
Gas 620 Ace 710	86 m	100 m ⁽¹⁾	100 m ⁽¹⁾
Gas 620 Ace 860	52 m	100 m ⁽¹⁾	100 m ⁽¹⁾
Gas 620 Ace 1000	26 m	70 m	100 m ⁽¹⁾
Gas 620 Ace 1150	10 m	32 m	48 m
Gas 620 Ace 1300	-	20 m	24 m

(1) While maintaining maximum length, additional 5 times 90° or 10 times 45° bends can be used (indicated for each boiler type and diameter).



■ Connection in different pressure zones (C₅₃)

The maximum permitted height difference between the air supply terminal and the flue gas outlet is 36 m.

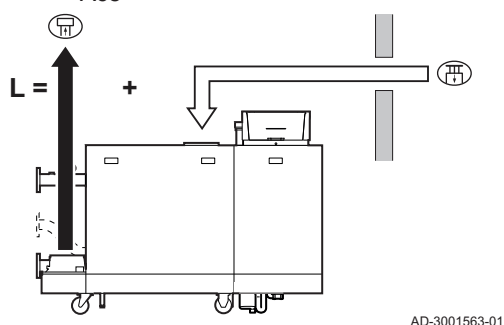
Fig.16 Different pressure zones Gas 320 Ace



AD-3001563-01

- L** Combined length of the flue and air supply channel
 Flue gas outlet connection
 Air supply connection

Tab.16 Maximum length (L)



Diameter ⁽¹⁾	250 mm	300 mm
Gas 320 Ace 285	100 m ⁽¹⁾	100 m ⁽¹⁾
Gas 320 Ace 355	100 m ⁽¹⁾	100 m ⁽¹⁾
Gas 320 Ace 430	88 m	100 m ⁽¹⁾
Gas 320 Ace 500	76 m	100 m ⁽¹⁾
Gas 320 Ace 575	53 m	100 m ⁽¹⁾
Gas 320 Ace 650	38 m	100 m ⁽¹⁾

(1) While maintaining maximum length, additional 5 times 90° or 10 times 45° bends can be used (indicated for each boiler type and diameter).

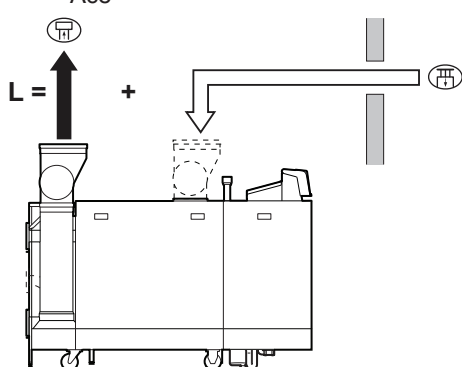
Fig.17 Different pressure zones Gas 620 Ace



AD-3001566-01

- L** Combined length of the flue and air supply channel
 Flue gas outlet connection
 Air supply connection

Tab.17 Maximum length (L)

Diameter ⁽¹⁾	300 mm	350 mm	400 mm
Gas 620 Ace 570	100 m ⁽¹⁾	100 m ⁽¹⁾	100 m ⁽¹⁾
Gas 620 Ace 710	48 m	100 m ⁽¹⁾	100 m ⁽¹⁾
Gas 620 Ace 860	24 m	83 m	100 m ⁽¹⁾
Gas 620 Ace 1000	-	38 m	90 m
Gas 620 Ace 1150	-	-	28 m
Gas 620 Ace 1300	-	-	-

(1) While maintaining maximum length, additional 5 times 90° or 10 times 45° bends can be used (indicated for each boiler type and diameter).

Fig.18 Bend radius 1D

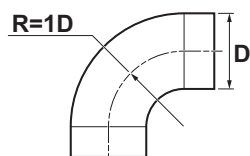

AD-3001609-01

■ Reduction table

Tab.18 Pipe reduction for each bend - radius 1D (parallel)

Diameter	250 mm	300 mm	350 mm	400 mm
45° bend	2.0 m	2.4 m	2.8 m	3.2 m
90° bend	3.5 m	4.2 m	4.9 m	5.6 m

4.5.5 Additional guidelines

■ Air supply filter

An air supply filter is separately available.

When installing the boiler in a room-ventilated setup (B₂₃, B_{23P}):

- It is recommended to install the air supply filter if the boiler is installed in a dusty room.
- It is mandatory to install the air supply filter if the boiler is exposed to construction dust.

■ Installation

- For installing the flue gas outlet and air supply materials, refer to the instructions of the manufacturer of the relevant material. After installation, check at least all flue gas outlet and air supply parts for tightness.



Warning

If the flue gas outlet and air supply materials are not installed in accordance with the instructions (e.g. not leak-proof, not correctly bracketed), this can result in dangerous situations and/or physical injury.

- Make sure that the flue gas outlet pipe towards the boiler has a sufficient gradient (at least 50 mm per metre) and that there is a sufficient condensate collector and discharge (at least 1 m before the outlet of the boiler). The bends used must be larger than 90° to guarantee the gradient and a good seal on the lip rings.

■ **Condensation**

- Direct connection of the flue gas outlet to structural ducts is not permitted because of condensation.
- If condensate from a plastic or stainless steel pipe section can flow back to an aluminium part in the flue gas outlet, this condensate must be discharged via a collector before it reaches the aluminium.
- Newly installed aluminium flue gas pipes with longer lengths can produce relatively larger quantities of corrosion products. Check and clean the siphon more often in this case.



Important

Contact us for more information.

4.6 Requirements for the electrical connections

- Establish the electrical connections in accordance with all local and national current regulations and standards.
- Electrical connections must always be made with the power supply disconnected and only by qualified installers.
- The boiler is completely pre-wired. Never change the internal connections of the control panel.
- Always connect the boiler to a well-earthed installation.
- The wiring must comply with the instructions in the electrical diagrams.
- Follow the recommendations in this manual.
- Separate the sensor cables from the 230 V cables

Make sure the following requirements are met when connecting the cables to the CB and SCB connectors:

Tab.19 PCB connectors

Wire cross section	Stripping length	Tightening torque
solid wire: 0.14 – 4.0 mm ² (AWG 26 – 12) stranded wire: 0.14 – 2.5 mm ² (AWG 26 – 14) stranded wire with ferrule: 0.25 – 2.5 mm ² (AWG 24 – 14)	8 mm	0.5 N·m

4.7 Water quality and water treatment

The quality of the heating water must comply with the limit values in our **Water quality instructions**. The guidelines in these instructions must be followed at all times. In many cases, the boiler and central heating system can be filled with normal tap water and water treatment will not be necessary.

4.8 Installation examples

4.8.1 How to use the installation examples

In this chapter, a few installation examples are given. Each example provides a quick overview of a simple hydraulic set-up, together with the connections that have to be made and the parameters to be set on the PCB's.

i Important

- To use these examples, basic installation knowledge is needed.
- This explanation shows schemes for the SCB-10 with an AD249 fitted. On a SCB-02, not all zones are available.

The installation example tables are laid out as follows:

The schemes are divided in columns. All relevant connections and settings are grouped per column.

Fig.19 Zone

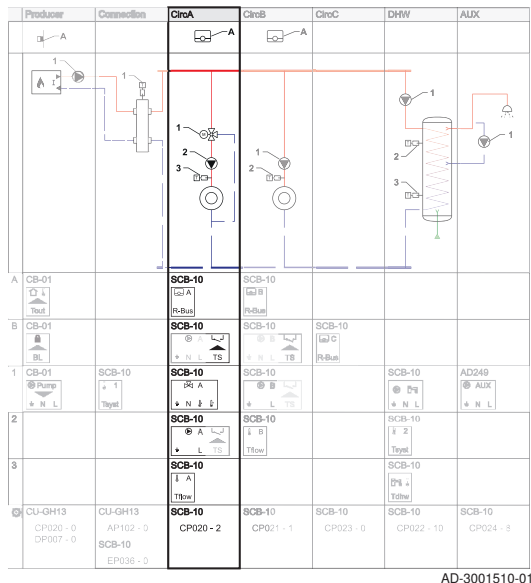
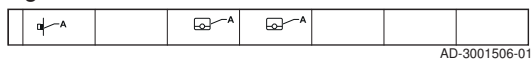
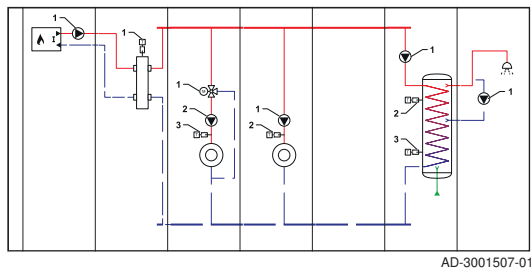

Fig.20 Heat demand



Heat demand: The top row shows the heat demand (if applicable) for the zone.

Fig.21 Hydraulic connections



Hydraulic connections: Only the essential parts are shown, parts to be connected to a PCB are numbered.

Fig.22 Electrical connections

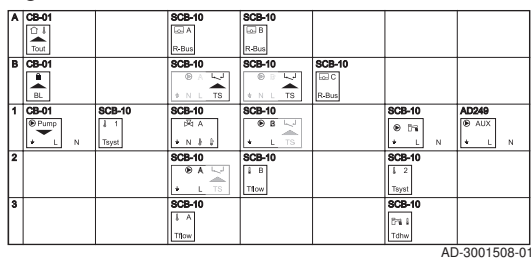

Electrical connections: The numbers in the hydraulic connections refer to the connectors on this row. There are multiple digits to identify the type of connection:

- A** Heat demand device.
- B** Bridge: These connectors must be bridged. Some bridges are already factory-fitted, some need to be fitted for the specific installation example.
- 1,2,...** The numbers in the hydraulic connections refer to the connectors on this row. Connect component no. 1 from the hydraulic scheme to the connector shown on line 1.

Fig.23 Parameters to be set

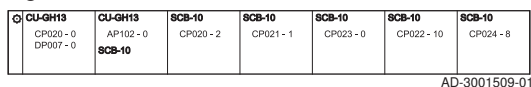

Parameters to be set: The parameters are separated per PCB, and must be set on that specific PCB.

The connectors can be found on the mentioned PCB. Take the following into account when making the connections:

Fig.24 Normal connector

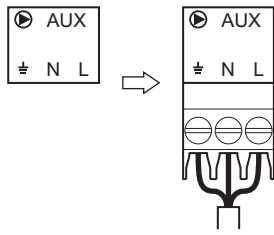

AD-3001511-01

Fig.25 Combined connector

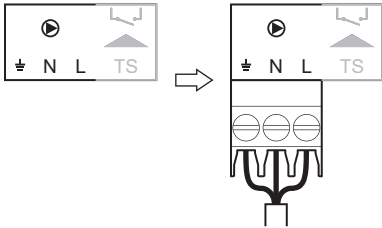

AD-3001512-01

These connectors combine two plugs into one connector. In the installation examples they appear with one highlighted part, which is to be used.

Fig.26 Connector to be bridged

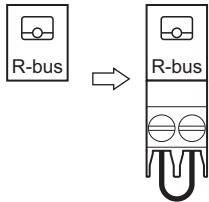

AD-3001513-01

Row **B** shows all connectors to be bridged. Connect a bridge to this connector.

Fig.27 Seven sections

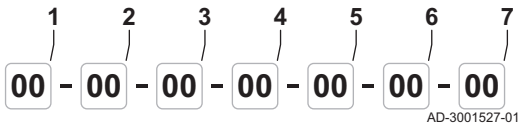

AD-3001527-01

4.8.2 How to find the desired installation example

Each example has a code describing the hydraulic set-up. The hydraulic code is built-up in seven sections. Each section consists of two numbers:

- 1 Number for the producer
- 2 Number for the connection
- 3 Number for zone 1 (CircA)
- 4 Number for zone 2 (CircB)
- 5 Number for zone 3 (CircC) (SCB-10 with AD249 addition required)
- 6 Number for zone 4 (DHW) (SCB-10 required)
- 7 Number for zone 5 (AUX) (SCB-10 with AD249 addition required)

The numbers of each section are linked to a specific configuration. Please see the following tables for the configuration:

Fig.28 Producer

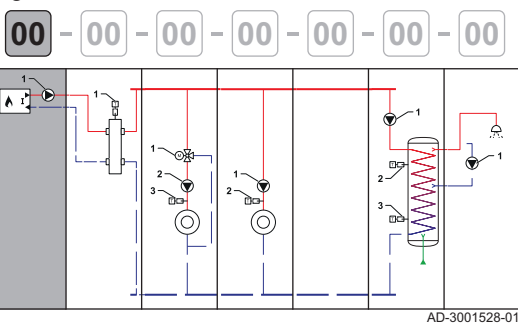

AD-3001528-01

Tab.20 Producer

Number	Description
00	Empty (no producer)
01	Boiler with primary heating circuit (no pump)
02	Boiler with primary heating circuit (internal pump)
03	Boiler with primary heating circuit (external pump)
04	Boiler with heating and domestic hot water (internal pump)
05	Boiler with heating and domestic hot water (external pump)
06	Boiler with primary and secondary heating circuit (internal pump)
07	Boiler with primary and secondary heating circuit (external pump)
08	Cascade of two boilers with primary heating circuit (no pump)
09	Cascade of three boilers with primary heating circuit (no pump)
10	Cascade of two boilers with primary heating circuit (internal pump)

Number	Description
11	Cascade of three boilers with primary heating circuit (internal pump)
12	Cascade of two boilers with primary heating circuit (external pump)
13	Cascade of three boilers with primary heating circuit (external pump)
14	Cascade of two boilers with primary and secondary heating circuit (internal pump)
15	Cascade of three boilers with primary and secondary heating circuit (internal pump)
16	Cascade of two boilers with primary and secondary heating circuit (external pump)
17	Cascade of three boilers with primary and secondary heating circuit (external pump)
18	Cascade of two boilers with primary heating circuit (no pump) + hydraulic valves
19	Cascade of two boilers with primary heating circuit (external pump) + hydraulic valves
20	Gas boiler and heat pump serial connected
21	Gas boiler and heat pump parallel connected

Fig.29 Connection

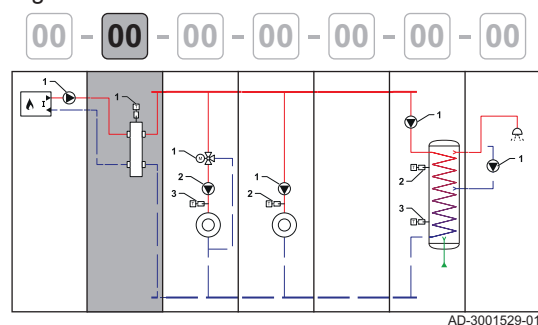

Tab.21 Connection

Number	Description
00	Empty (no connection)
01	Direct connection
02	Low loss header
03	Plate heat exchanger
04	Buffer tank with one sensor
05	Buffer tank with two sensors
06	Buffer tank with electrical heating
07	Buffer tank with solar heating
08	Low loss header with Tflow sensor

Fig.30 Zone 1 (CircA)

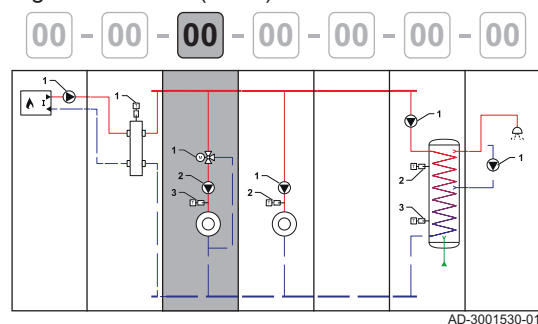

Tab.22 Zone 1 (CircA)

Number	Description
00	Empty (no zone)
01	Direct circuit
02	Mixing circuit
03	Swimming pool (direct)
04	High temperature
05	Fan convector (direct)
06	Domestic hot water tank
07	Domestic hot water tank (electrical)
08	Time program
09	Process heat
10	Domestic hot water tank (layered)
11	Domestic hot water tank (internal)
12	Underfloor heating (mixing)
13	Heat interface unit

4 Before installation

Fig.31 Zone 2 (CircB)

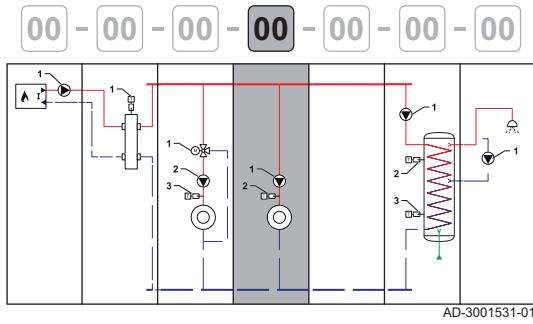

Tab.23 Zone 2 (CircB)

Number	Description
00	Empty (no zone)
01	Direct circuit
02	Mixing circuit
03	Swimming pool (direct)
04	High temperature
05	Fan convector (direct)
06	Domestic hot water tank
07	Domestic hot water tank (electrical)
08	Time program
09	Process heat
10	Domestic hot water tank (layered)
11	Domestic hot water tank (internal)
12	Underfloor heating (mixing)
13	Heat interface unit

Fig.32 Zone 3 (CircC)

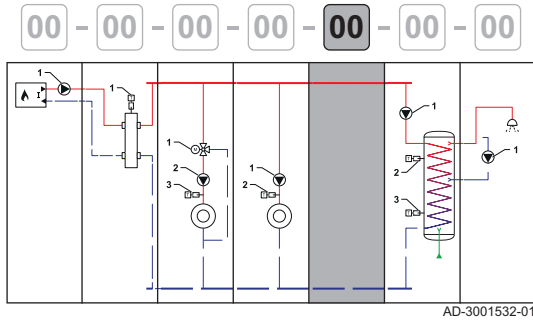

Tab.24 Zone 3 (CircC) (SCB-10 with AD249 addition required)

Number	Description
00	Empty (no zone)
01	Direct circuit
02	Mixing circuit
03	Swimming pool (direct)
04	High temperature
05	Fan convector (direct)
06	Domestic hot water tank
07	Domestic hot water tank (electrical)
08	Time program
09	Process heat
10	Domestic hot water tank (layered)
11	Domestic hot water tank (internal)
12	Underfloor heating (mixing)
13	Heat interface unit

Fig.33 Zone 4 (DHW)

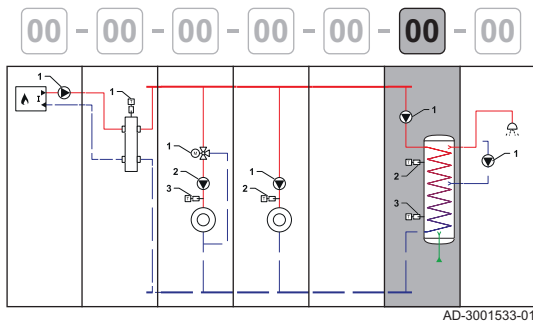

Tab.25 Zone 4 (DHW) (SCB-10 required)

Number	Description
00	Empty (no zone)
01	Domestic hot water tank with one sensor and pump
02	Domestic hot water tank with two sensors and pump
03	Domestic hot water tank with solar heating
04	Domestic hot water tank with electrical heating
05	Domestic hot water tank with one sensor

Fig.34 Zone 5 (AUX)

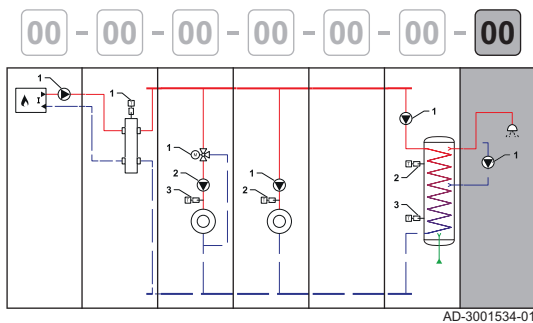





Tab.26 Zone 5 (AUX) (SCB-10 with AD249 addition required)





Number	Description
00	Empty (no zone)
01	Domestic hot water loop (with pump)
02	Domestic hot water (without pump)
03	Time program (on/off pump output)
04	Process heat (24/7 only this zone possible)
05	Domestic hot water tank (internal)

4.8.3 Symbols used



Tab.27 Tubing

Symbol	Explanation	Symbol	Explanation
	Flow pipe		Return pipe
	Flow collector pipe		Return collector pipe
	Drinking water supply		

Tab.28 Hydraulic components

Symbol	Explanation	Symbol	Explanation
	Mixing valve		Valve, electronically actuated
	Plate heat exchanger		Low loss header
	Pump		

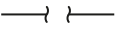

Tab.29 Sensors and contacts

Symbol	Explanation	Symbol	Explanation
	Outdoor temperature sensor		Temperature sensor
	Safety thermostat		Electrical cable







Tab.30 Heat demand sources

Symbol	Explanation	Symbol	Explanation
	Room thermostat	0-10V	0-10V input

Tab.31 Heat producers









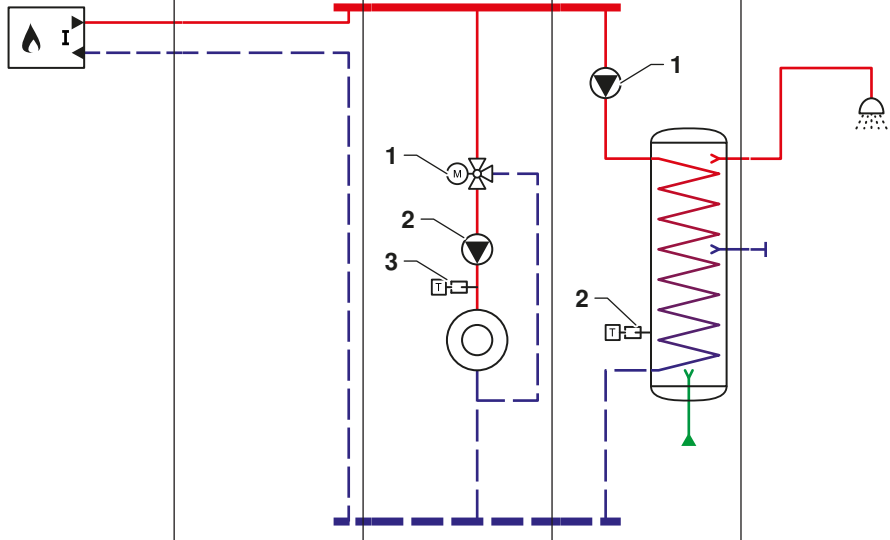

Symbol	Explanation	Symbol	Explanation
	(Gas) Fueled boiler - single circuit		Heat pump
	(Gas) Fueled boiler - double circuit		

Tab.32 Heat consumers

Symbol	Explanation	Symbol	Explanation
	Heating zone		Hot air heating zone
	Radiator		Underfloor heating
	Water tap		Shower

4.8.4 SCB-02 Installation example 01-01-02-10-00-00-00

Tab.33 Hydraulic and electrical connections for: Boiler with primary heating circuit (no pump) - Direct connection - Mixing circuit - Domestic hot water tank with one sensor and pump

Producer	Connection	CircA	CircB			
01	01	02	10	00	00	00
 A AD-3001435-01		 A AD-3001437-01				
						
AD-3001484-01	AD-3001475-01	AD-3001432-01	AD-3001538-01	AD-3001486-01		
A CB-01 		SCB-02 				
B CB-01 (1) 						
1		SCB-02 	SCB-02 			
2		SCB-02 	SCB-02 			
3		SCB-02 				
(1) Bridge: These connectors must be bridged. Some bridges are already factory-fitted, some need to be fitted for this specific installation example.						

Tab.34 CircA - parameters to be set









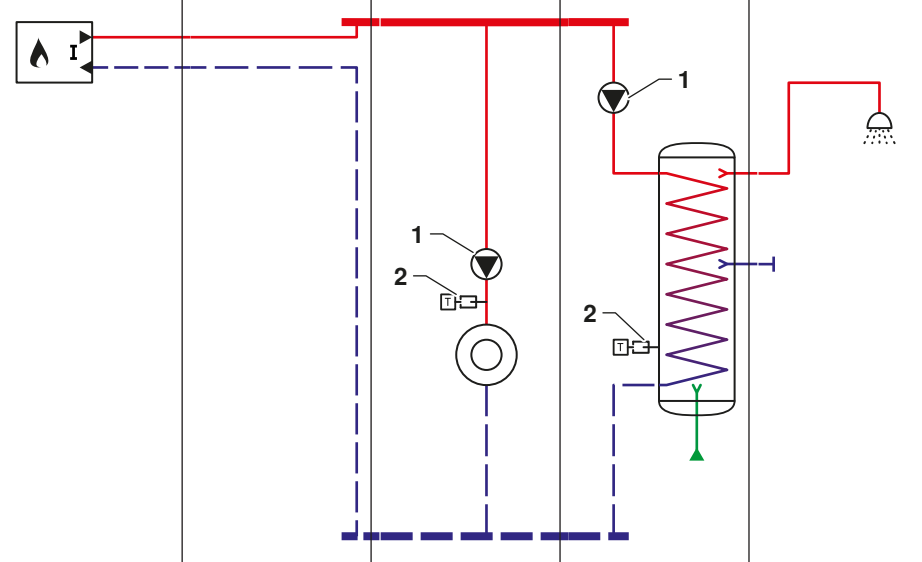

Code	Display text	Menu path	Set to
CP020	Zone Function	≡ > Installation Setup > SCB-02 > CIRCA 1 > Parameters, counters, signals > Parameters	2 = Mixing Circuit

Tab.35 CircB - parameters to be set

Code	Display text	Menu path	Set to
CP021	Zone Function	≡ > Installation Setup > SCB-02 > CIRCB 1 > Parameters, counters, signals > Parameters	10 = DHW Layered

4.8.5 SCB-02 Installation example 01-01-01-10-00-00-00

Tab.36 Hydraulic and electrical connections for: Boiler with primary heating circuit (no pump) - Direct connection - Direct circuit - Domestic hot water tank with one sensor and pump

Producer	Connection	CircA	CircB			
01	01	01	10	00	00	00
 AD-3001435-01		 AD-3001437-01				
						
AD-3001484-01	AD-3001475-01	AD-3001464-01	AD-3001538-01	AD-3001486-01		
A	CB-01  Tout	SCB-02  R-Bus				
B	CB-01 (1)  BL					
1		SCB-02  ≡ N L	SCB-02  ≡ N L			
2		SCB-02  Tflow	SCB-02  Tdhw			
(1) Bridge: These connectors must be bridged. Some bridges are already factory-fitted, some need to be fitted for this specific installation example.						

Tab.37 CircA - parameters to be set

Code	Display text	Menu path	Set to
CP020	Zone Function	☰ > Installation Setup > SCB-02 > CIRCA 1 > Parameters, counters, signals > Parameters	1 = Direct

Tab.38 CircB - parameters to be set

Code	Display text	Menu path	Set to
CP021	Zone Function	☰ > Installation Setup > SCB-02 > CIRCB 1 > Parameters, counters, signals > Parameters	10 = DHW Layered

5 Installation

5.1 Positioning the boiler

Refer to the **lifting instructions document** on how to unpack and transport the boiler to the location.

1. Manoeuvre the boiler to the exact location.
2. Unscrew the levelling feet until they stand firmly on the floor.

Fig.35 Place the boiler

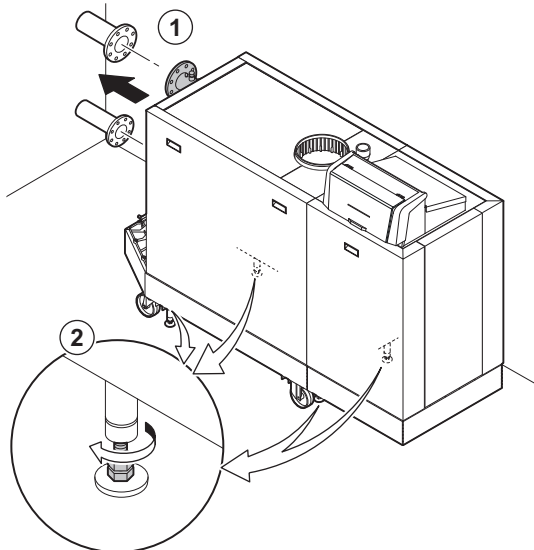

AD-3001416-02

Fig.36 Open the casing

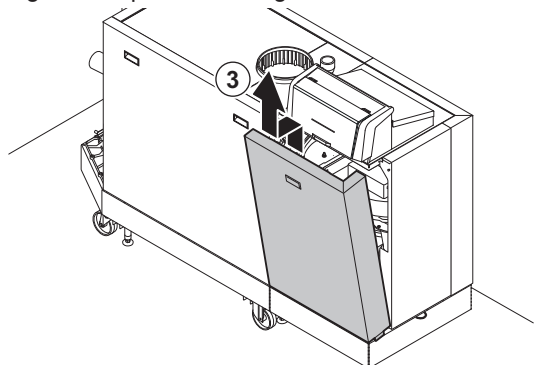

AD-3001417-02

3. Open the casing by lifting up the front panel and taking it off.

Fig.37 Level the boiler

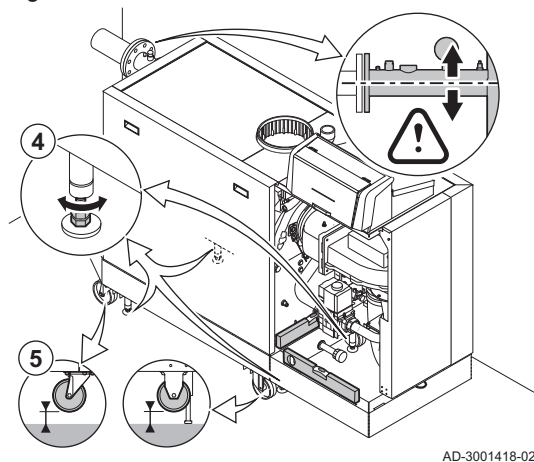

AD-3001418-02

4. Adjust the levelling feet to level the boiler.
5. Check if the boiler is resting solely on the levelling feet (transport wheels must be off the floor).

5.2 Rotating the control box

If the installation location obstructs the display, the control box can be rotated. Proceed as follows:

Fig.38 Open the control box

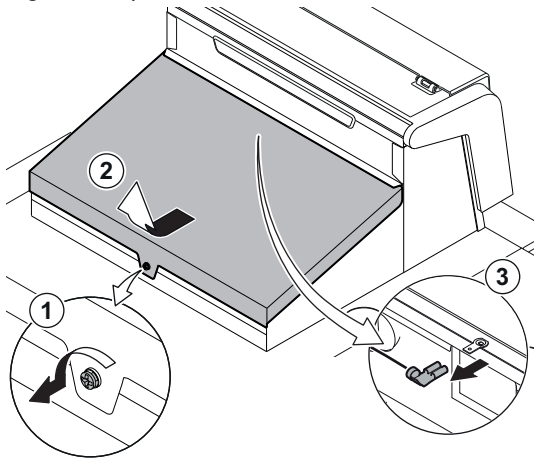

AD-3001868-01

1. Undo the quarter turn screw.
2. Remove the cover.
3. Disconnect the earth wire from the cover.

Fig.39 Lift up the PCB mounting plate

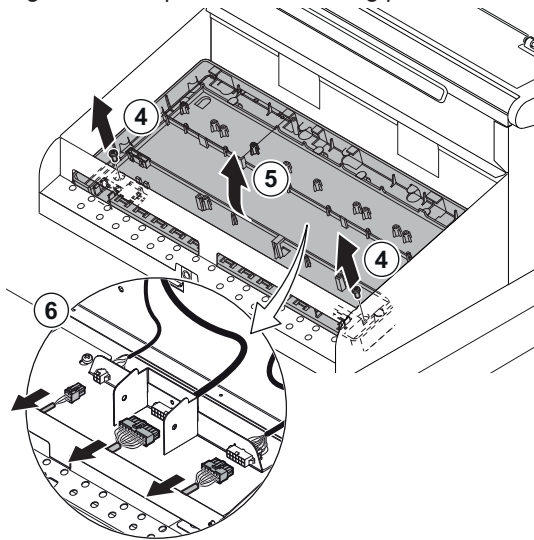

AD-3001869-01

4. Unscrew the two screws at the bottom of the PCB mounting plate.
5. Lift up the PCB mounting plate.
6. Disconnect the three electrical connectors located under the PCB mounting plate.

Fig.40 Loosen the control box frame

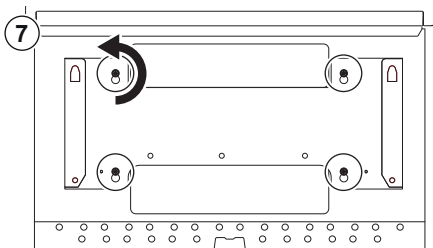

AD-3001870-01

7. Unscrew the four screws that are holding the control box frame in place.

Fig.41 Rotate the control box

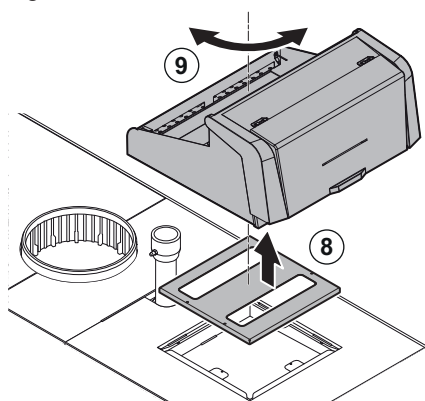

AD-3001871-01

8. Lift up the control box and the mounting plate.
9. Rotate the control box and the mounting plate into the desired direction.
10. Reassemble in reverse order.

5.3 Connecting the heating circuit

Fig.42 Connecting the heating circuit

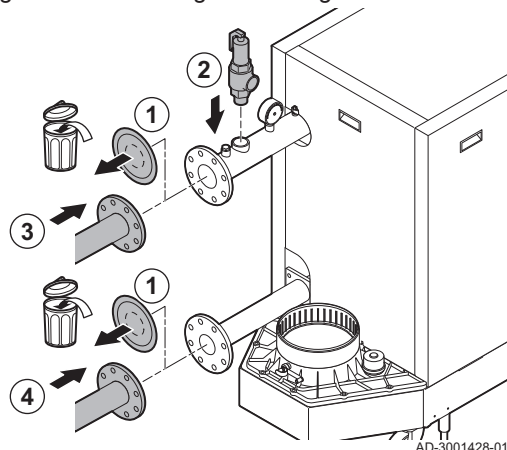

For boiler Gas 620 Ace, apply the instructions to each boiler module.

1. Remove the dust caps from the flow and return connections.
2. Connect a safety valve to the flow connection.
3. Fit the system flow pipe to the flow connection.
4. Fit the system return pipe to the return connection.

5.4 Connecting the condensate discharge pipe

Fig.43 Connecting the condensate discharge pipe

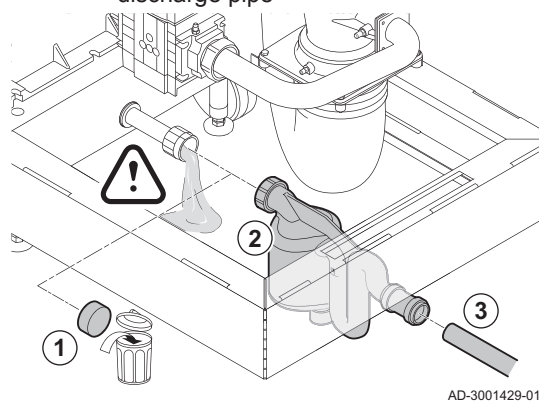

For boiler Gas 620 Ace, apply the instructions to each boiler module.

1. Remove the protective cap from the condensate connection.



Caution

Water from the factory test may come out.

2. Fit the siphon by screwing the swivel nut onto the connection.
3. Fit a plastic drain pipe of \varnothing 32 mm or larger to the siphon, terminating in the drain.

5.5 Connecting the gas pipe

Fig.44 Connecting the gas pipe

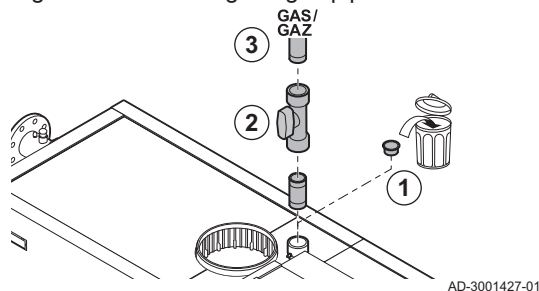

For boiler Gas 620 Ace, apply the instructions to each boiler module.

The gas pipe must be free of dirt and dust. The boiler is fitted with a gas filter as standard.



Warning

Before starting work on the gas pipes, turn off the main gas tap.

1. Remove the dust cap from the gas connection GAS/GAZ .
2. Fit a gas valve near the boiler.
3. Fit the gas supply pipe to the gas supply GAS/GAZ .

5.6 Connecting the air inlet and flue gas outlet

Fig.45 Fit the flue gas outlet pipe to the boiler

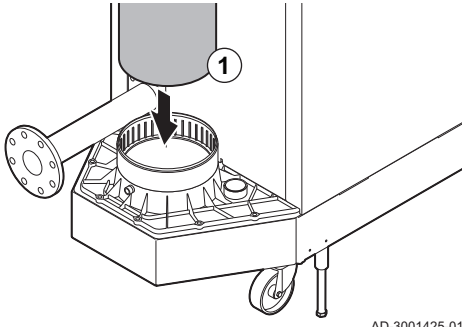

AD-3001425-01

1. Fit the flue gas outlet pipe to the boiler.
2. Fit the subsequent flue gas outlet pipes in accordance with the manufacturer's instructions.



Caution

- The pipes must not be resting on the boiler.
- Fit the horizontal parts sloping down towards the boiler, with a slope of 50 mm per metre.

Fig.46 Fit the air inlet pipe to the boiler

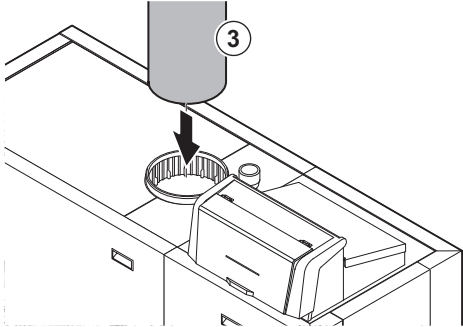

AD-3001426-02

3. Fit the air supply pipe to the boiler.
4. Fit the subsequent air supply pipes in accordance with the manufacturer's instructions.



Caution

- The pipes must not be resting on the boiler.
- Fit the horizontal parts sloping down towards the air supply outlet.

5.7 Electrical connections

5.7.1 PCB locations

This illustration shows the location for each PCB. Both factory-fitted and optional PCBs are shown.

Fig.47 PCB locations

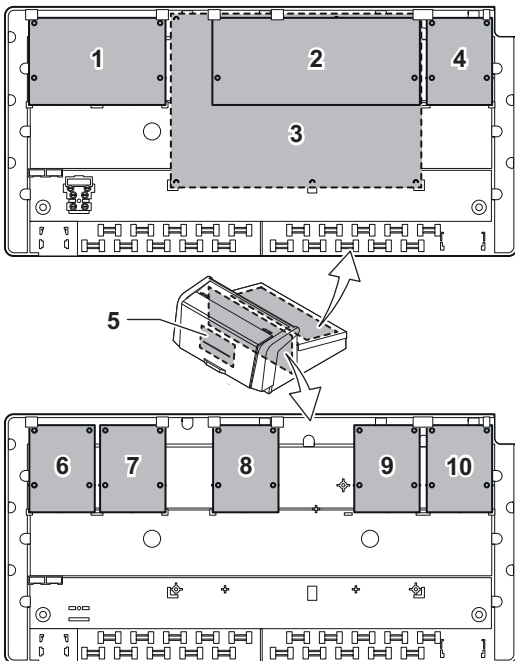

AD-3001591-01

device	primary location	location option
CU-GH13	5	-
CB-01	1	-
SCB-01	7	8
SCB-02	2	-
SCB-10 (optional)	3	-
SCB-13 (optional)	4	6
GTW-08 (optional)	7	-
BLE Smart Antenna	10	-
GTW-30 (optional)	8	9

Fig.48 Connection PCB CB-01

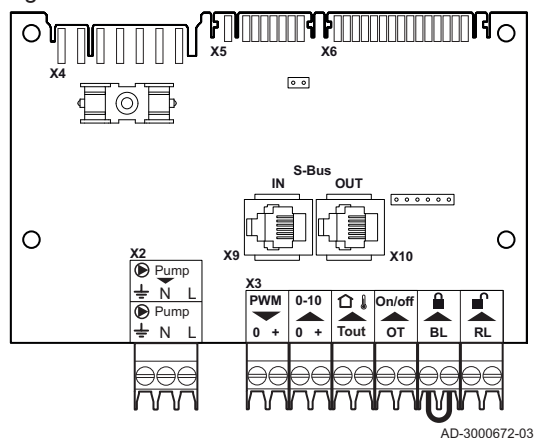

5.7.2 The CB-01 connection PCB

The **CB-01** is placed in the control box. It provides easy access to all the standard connectors.

Fig.49 System pump

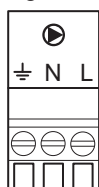

AD-3001306-01

Fig.50 PWM system pump

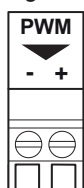

AD-3001307-01

Fig.51 Analogue input

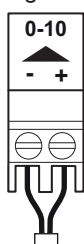

AD-3001304-01

■ Connecting the system pump

1. Connect a system pump to the **Pump** terminals of the connector.



Important

The maximum power consumption is 300 VA.

The function of the system pump can be changed using parameters **PP015**, **PP016** and **PP018**.

■ Connecting a PWM system pump

A PWM system pump can be connected to the boiler and can be controlled in a modulating way from the boiler

1. Connect the PWM pump to the **PWM** terminals of the connector.



Important

Contact us for more information.

■ Analogue input

This input has two modes: control based on temperature or based on heat output. If this input is used, the OT communication from the boiler is ignored.

1. Connect the input signal to terminals **0-10** of the connector.

Change the mode of the analogue input using the parameter **EP014**.

Fig.52 Temperature regulation

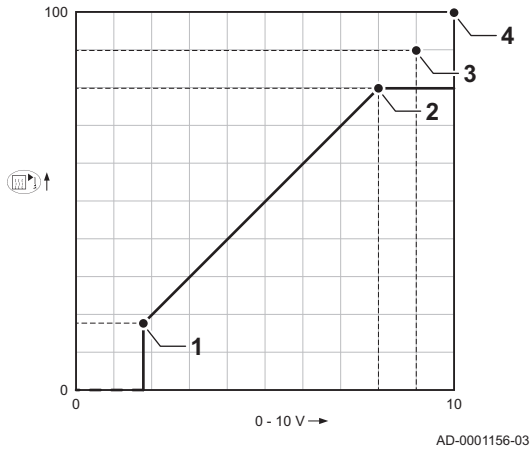

- Analogue temperature regulation (°C)

- 1 Boiler on
- 2 Parameter CP010
- 3 Maximum flow temperature
- 4 Calculated value

The 0–10 V signal controls the boiler supply temperature. This control modulates on the basis of flow temperature. The output varies between the minimum and maximum value on the basis of the flow temperature set point calculated by the controller.

Tab.39 Temperature regulation

Input signal (V)	Temperature °C	Description
0–1.5	0–15	Boiler off
1.5–1.8	15–18	Hysteresis
1.8–10	18–100	Desired temperature

- Analogue output-based control

The 0 - 10 V signal controls the boiler output. This control modulates on the basis of the heat output. The minimum output is linked to the boiler's modulation depth. The output varies between the minimum and maximum value on the basis of the value defined by the controller.

Tab.40 Control based on heat output

Input signal (V)	Heat output (%)	Description
0–2.0	0	Boiler off
2.0–2.2	0	Heat demand
2.0–10	0–100	Desired heat output

■ Connecting an outdoor temperature sensor

An outdoor temperature sensor can be connected to the **Tout** connector. Always connect the sensor to the PCB that controls the zones. For example: when the zones are controlled by an SCB-02 or SCB-10, connect the sensor to that PCB.

1. Connect the two-wire cable to the **Tout** connector.

Set parameter **AP056** to the installed outdoor temperature sensor type.

When an on/off thermostat is also connected, the boiler will control the temperature with the set point from the internal heating curve. **OpenTherm** controllers can also use the outdoor temperature sensor. In that case, the desired heating curve must be set on the controller.

■ Room thermostat connector (On/off - OT)

The **On/off - OT** connector can be used to connect a room thermostat. The connector supports the following types:

- **OpenTherm** thermostat (for example, the **iSense**)
- **OpenTherm Smart Power** thermostat
- **On/off** thermostat

It does not matter which wire is connected to which cable clamp. The software recognizes which type of thermostat is connected.

Fig.53 Tout connector

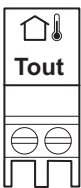

AD-4000006-02

Fig.54 On/off - OT connector

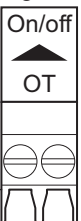

AD-3001599-02

■ Blocking input



Caution

Only suitable for potential-free contacts (dry contact).



Important

First remove the bridge if this input is used.

Fig.55 Blocking input



AD-3000972-02

The boiler has a blocking input. A potential-free contact can be connected to the **BL** terminals of the connector. If the contact is opened, the boiler will be blocked.

Change the function of the input using parameter **AP001**. This parameter has the following 3 configuration options:

- Complete blocking: no frost protection with the outdoor sensor and no boiler frost protection (pump does not start and burner does not start)
- Partial blocking: boiler frost protection (pump starts when the temperature of the heat exchanger is $< 6^{\circ}\text{C}$ and the burner starts when the temperature of the heat exchanger is $< 3^{\circ}\text{C}$)
- Lock out: no frost protection with outdoor sensor and partial boiler frost protection (pump starts when the temperature of the heat exchanger is $< 6^{\circ}\text{C}$, the burner does not start when the temperature of the heat exchanger is $< 3^{\circ}\text{C}$).

■ Release input



Caution

Only suitable for potential-free contacts (dry contact).

Fig.56 Release input

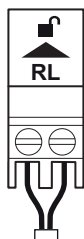

AD-3001303-01

The boiler has a release input. A potential-free contact can be connected to the **RL** terminals of the connector.

- If the contact is closed during a heat demand, the boiler will be blocked immediately.
- If the contact is closed when there is no heat demand, the boiler will be blocked after a waiting time.

Change the waiting time of the input using parameter **AP008**.

Fig.57 SCB-01 PCB

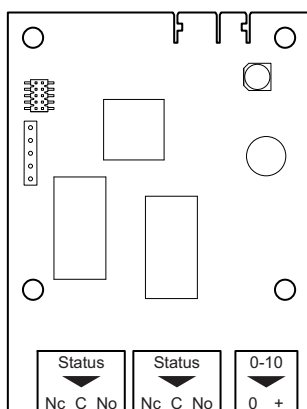

AD-3001514-01

5.7.3 The SCB-01 expansion PCB

The SCB-01 has the following features:

- Two potential free contacts for status notifications
- 0–10 V output connection for a PWM system pump

Expansion PCBs are automatically recognised by the control unit of the boiler. If expansion PCBs are removed, the boiler will show an error code. To resolve this error, an auto-detect must be carried out after removal.

■ Connecting status notifications

The two potential-free contacts, **Status**, can be configured as required. Depending on the setting, a particular status can be transmitted by the boiler.

Fig.58 Status notifications

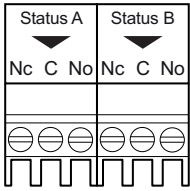

AD-3001312-01

Connect a relais as follows:

- Nc** Normally closed contact. Contact will open when status occurs.
- C** Main contact.
- No** Normally opened contact. Contact will close when status occurs.

Select the desired status notification (setting) using parameter **EP018** and **EP019**.

■ **Connecting 0–10 V output**

Fig.59 0–10 V output connector

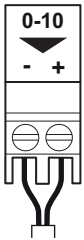

AD-3001305-01

The **0-10** contact can be used to connect a PWM system pump. The speed of the pump is modulated based on the signal received from the boiler. Depending on the make and type of pump, the pump can be controlled by a 0–10 V or a PWM signal.

Connect the system pump controller to connector **0-10**.

- Select the type of signal that will be sent from the boiler using the parameter **EP029**.
- Select the type of signal that controls the pump using the parameter **EP028**.

Caution

- If possible, use the pump modulation signal. This provides the most accurate pump control.
- If the automatic burner unit does not support pump modulation, the pump will behave as an on/off pump.

5.7.4 The SCB-02 expansion PCB

Fig.60 SCB-02 PCB

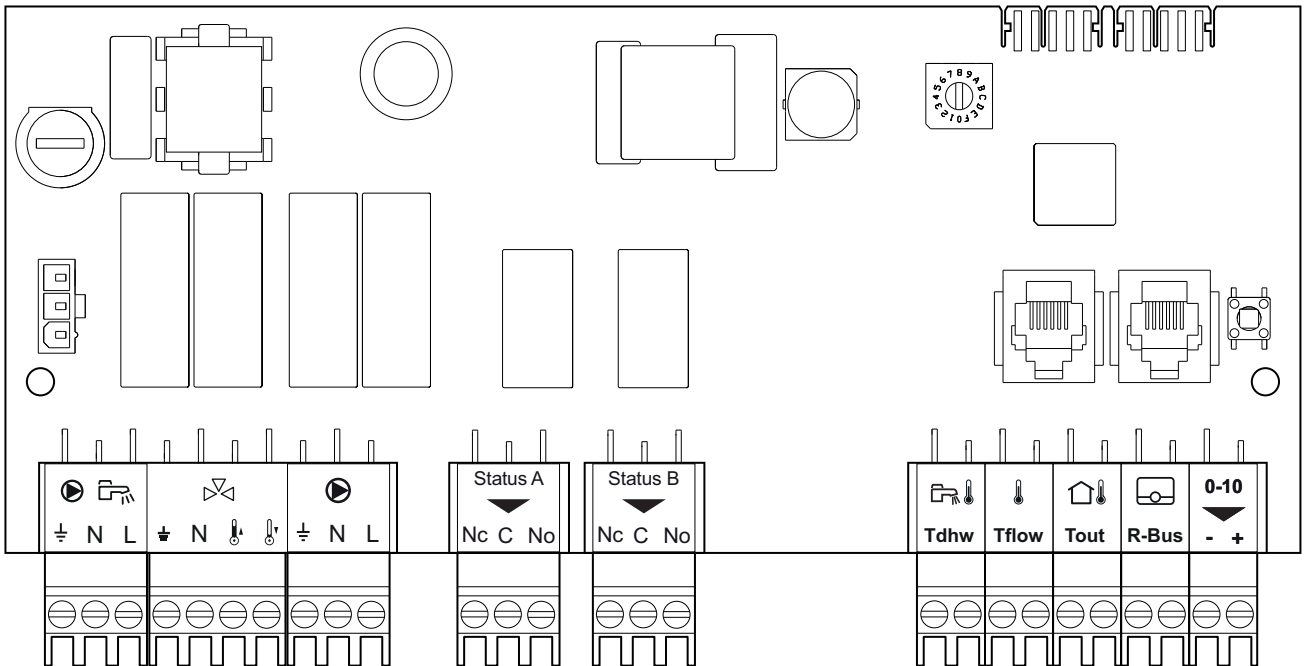

AD-3001313-01

The SCB-02 has the following features:

- Control of a (mixing) zone for heating (or cooling)
- Control of one domestic hot water (DHW) zone
- 0–10 V output connection for a PWM system pump
- Two potential-free contacts for status notifications

Expansion PCBs are automatically recognised by the control unit of the boiler. If expansion PCBs are removed, the boiler will show an error code. To resolve this error, an auto-detect must be carried out after removal.

Fig.61 DHW pump connector

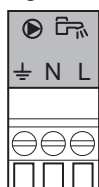

AD-4000123-01

■ Connecting a domestic hot water (DHW) pump

Connecting a domestic hot water (DHW) pump. The maximum power consumption is 300 VA.

Connect the pump as follows:

- ⏏ Earth
- N Neutral
- L Phase

Fig.62 Mixing valve connector

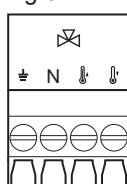

AD-4000015-03

■ Connecting a mixing valve

The mixing valve connector can be used to connect a mixing valve (230 VAC) for use in a boiler group (zone).

Connect the mixing valve as follows:

- ⏏ Earth
- N Neutral
- ⏏ Open
- ⏏ Close

Fig.63 System pump

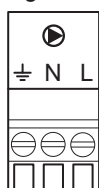

AD-3001306-01

■ Connecting the system pump

1. Connect a system pump to the **Pump** terminals of the connector.



Important

The maximum power consumption is 300 VA.

The function of the system pump can be changed using parameters **PP015**, **PP016** and **PP018**.

■ Connecting status notifications

The two potential-free contacts, **Status**, can be configured as required. Depending on the setting, a particular status can be transmitted by the boiler.

Connect a relais as follows:

- Nc** Normally closed contact. Contact will open when status occurs.
- C** Main contact.
- No** Normally opened contact. Contact will close when status occurs.

Select the desired status notification (setting) using parameter **EP018** and **EP019**.

Fig.64 Status notifications

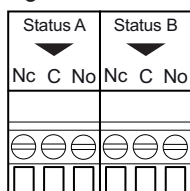

AD-3001312-01

■ Connecting the calorifier sensor/thermostat

A calorifier sensor or thermostat can be connected to the **Tdhw** terminals of the connector. Only NTC 10 kΩ/25°C sensors can be used.



Important

For boilers with an SCB-10 PCB, the calorifier sensor/thermostat must be connected to the SCB-10 PCB.

Fig.65 Connecting the calorifier sensor/ thermostat



AD-3000971-02

1. Connect the two-wire cable to the **Tdhw** terminals of the connector.

■ **Connecting a zone temperature sensor**

A zone temperature sensor can be connected to the **Tflow** terminals of the connector.

1. Connect the two-wire cable to the **Tflow** terminals of the connector.

Fig.66 Tflow connector

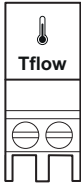

AD-3001311-01

■ **Connecting an outdoor temperature sensor**

An outdoor temperature sensor can be connected to the **Tout** connector. Always connect the sensor to the PCB that controls the zones. For example: when the zones are controlled by an SCB-02 or SCB-10, connect the sensor to that PCB.

1. Connect the two-wire cable to the **Tout** connector.

Set parameter **AP056** to the installed outdoor temperature sensor type.

When an on/off thermostat is also connected, the boiler will control the temperature with the set point from the internal heating curve. **OpenTherm** controllers can also use the outdoor temperature sensor. In that case, the desired heating curve must be set on the controller.

Fig.67 Tout connector

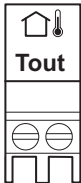

AD-4000006-02

■ **Connecting thermostats**

The **R-Bus** connector can be used to connect a room thermostat. The connector supports the following types:

- **R-Bus** thermostat (for example, the **eTwist**)
- **OpenTherm** thermostat (for example, the **iSense**)
- **OpenTherm Smart Power** thermostat
- **On/off** thermostat

It does not matter which wire is connected to which cable clamp. The software recognizes which type of thermostat is connected.

Fig.68 R-Bus connector

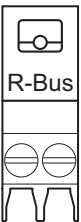

AD-3001314-02

■ **Connecting 0–10 V output**

The **0-10** contact can be used to connect a PWM system pump. The speed of the pump is modulated based on the signal received from the boiler. Depending on the make and type of pump, the pump can be controlled by a 0–10 V or a PWM signal.

Connect the system pump controller to connector **0-10**.

- Select the type of signal that will be sent from the boiler using the parameter **EP029**.
- Select the type of signal that controls the pump using the parameter **EP028**.

Fig.69 0–10 V output connector

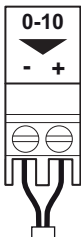

AD-3001305-01

**Caution**

- If possible, use the pump modulation signal. This provides the most accurate pump control.
- If the automatic burner unit does not support pump modulation, the pump will behave as an on/off pump.

5.7.5 Connecting the power cable

The power connection is located in the rear part of the control box. The power connection is fitted with a 10AT fuse.

**Danger of electric shock**

Always turn off the main power before working on the electrical connections.

Make sure the following requirements are met when connecting the power cable:

Tab.41 Power connection

Wire cross section	Stripping length	Tightening torque
solid wire: 2.5 mm ² (AWG 14) stranded wire: 2.5 mm ² (AWG 14) stranded wire with ferrule: 2.5 mm ² (AWG 14)	7 mm	0.5 N·m

Fig.70 Connecting the power cable

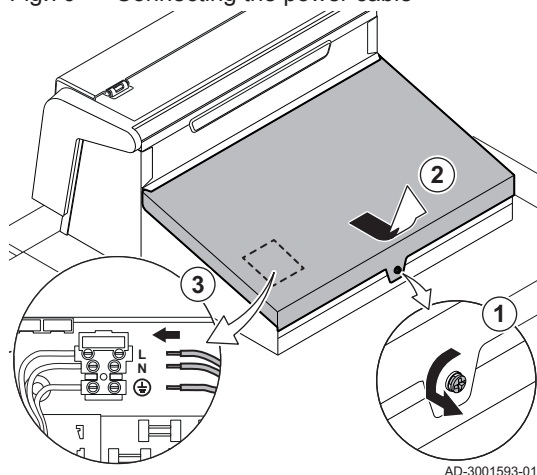

AD-3001593-01

1. Undo the quarter turn screw.
2. Remove the cover.
3. Connect the power cable to the connector block.
4. Close the cover.
5. Tighten the quarter turn screw.

5.7.6 Cable routing in the control box front part



Caution

Make sure the cable routing matches the illustration when closing the control box.

Fig.71 Cable routing in the control box front part

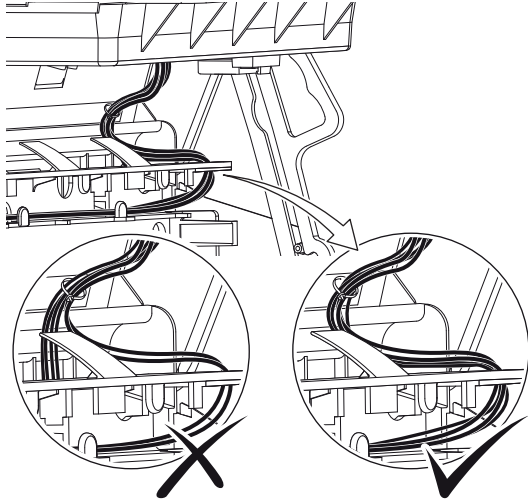

AD-3001768-01

6 Preparation of commissioning

6.1 Checklist before commissioning

Fig.72 Filling and drain valve location

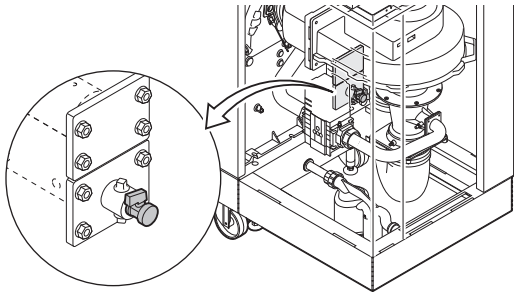

AD-3001559-01

6.1.1 Filling the installation

The recommended water pressure is between 1.5 bar and 2.0 bar.

Proceed as follows to fill the installation:

1. Disconnect the boiler from the power supply.
2. Fill the central heating system with clean water, using the filling and drain valve (½", fitted on the front section).
3. Check the water-side connections for tightness.
4. Power up the boiler.

6.1.2 Filling the siphon



Danger

The siphon must always be sufficiently filled with water. This prevents flue gases from entering the room.

Fig.73 Filling the siphon

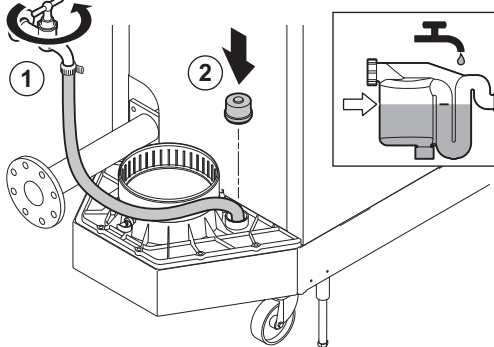

AD-3001600-01

1. Fill the siphon up to the mark via the condensate collector.
2. Put the sealing cap back on the condensate collector.

Fig.74 Gas inlet pressure measuring point

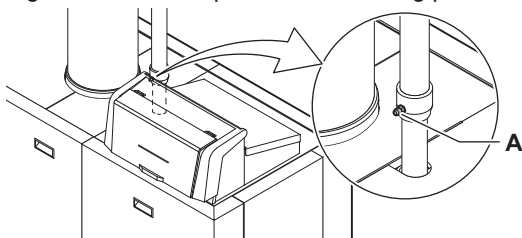

AD-3001560-01

6.1.3 Preparing the gas circuit



Warning

Ensure that the boiler is disconnected from the power supply.

1. Open the main gas valve.
2. Open the boiler gas valve.
3. Check the tightness of the gas circuit.
4. Vent the gas supply pipe by unscrewing measuring point **A**.
⇒ The gas supply pipe is properly vented when a gas smell can be noticed.
5. Check the gas inlet pressure at measuring point **A**.
⇒ The pressure must be the same as the one shown on the data plate.
6. Tighten the measuring point again.

6.2 Control panel description

Fig.75 Control panel components

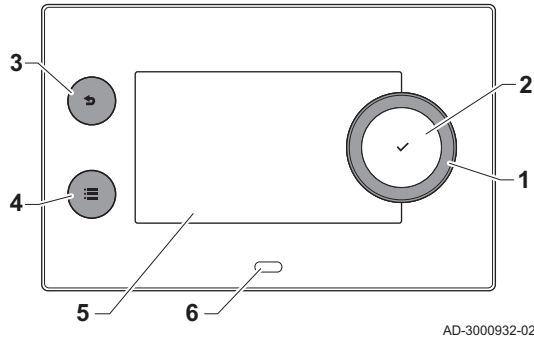

6.2.1 Control panel components

- 1 Rotary knob to select a tile, menu or setting
- 2 Confirm button ✓ to confirm the selection
- 3 Back button ⇨:
 - **Short button press:** Return to the previous level or previous menu
 - **Long button press:** Return to home screen
- 4 Menu button ≡ to go to the main menu
- 5 Display
- 6 Status LED

6.2.2 Description of the home screen

This screen is shown automatically after start-up of the appliance. The control panel goes automatically in standby mode (black screen) if the screen is not touched for 5 minutes. Press one of the buttons on the control panel to activate the screen again.

You can navigate from any menu to the home screen by pressing the back button ⇨ for several seconds.

The tiles on the home screen provide quick access to the corresponding menus. Use the rotary knob to navigate to the menu of your choice and press the button ✓ to confirm the selection.

Fig.76 Icons on home screen

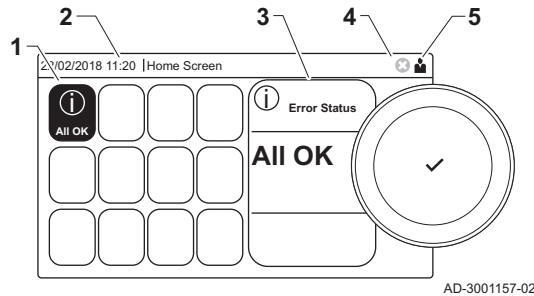

- 1 Tiles: the selected tile is highlighted
- 2 Date and time | Name of the screen (actual position in the menu)
- 3 Information about the selected tile
- 4 Error indicator (only visible if an error has been found)
- 5 Icon showing the navigation level:
 - 🏠: Chimney sweeper level
 - 👤: User level
 - 🛠️: Installer level

The installer level is protected by an access code. When this level is active, the status of the tile [🛠️] changes from **Off** into **On**.

6.2.3 Description of the main menu

You can navigate from any menu directly to the main menu by pressing the menu button ≡. The number of accessible menus depends on the access level (user or installer).

Fig.77 Items in the main menu

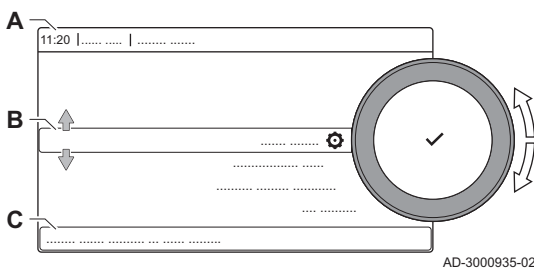





- A Date and time | Name of the screen (actual position in the menu)
- B Available menus
- C Brief explanation of the selected menu

Tab.42 Available menus for the user 👤





























Description	Icon
System Settings	⚙️
Version Information	i

Tab.43 Available menus for the installer 







Description	Icon
Installation Setup	
Commissioning Menu	
Advanced Service Menu	
Error History	
System Settings	
Version Information	i

6.2.4 Meaning of the icons in the display

Tab.44 Icons

Icon	Description
	User menu: user-level parameters can be configured.
	Installer menu: installer-level parameter can be configured.
i	Information menu: read out various current values.
	System settings: system parameters can be configured.
	Error indicator.
	Gas boiler indicator.
	Domestic hot water tank is connected.
	The outdoor temperature sensor is connected.
	Boiler number in cascade system.
	The solar calorifier is on and its heat level is displayed.
	CH operation is enabled.
	CH operation is disabled.
	DHW operation is enabled.
	DHW operation is disabled.
	The burner is on.
	The burner is off.
	Burner output level (1 to 5 bars, with each bar representing 20% output).
	The pump is running.
	Three-way valve indicator.
	Display of the system water pressure.
	Chimney sweep mode is enabled (forced full load or low load for O ₂ /CO ₂ measurement).
	Energy-saving mode is enabled.
	DHW boost is enabled.
	Timer program is enabled: The room temperature is controlled by a timer program.
	Manual mode is enabled: The room temperature is set to a fixed setting.
	Temporary overwrite of the timer program is enabled: The room temperature is changed temporarily.
	The holiday program (including frost protection) is active: The room temperature is reduced during your holiday to save energy.
	Frost protection is enabled: Protect the boiler and installation from freezing in winter.
	Installer contact details are displayed or can be filled in.

Tab.45 Icons - Zones

Icon	Description
	All zones (groups) icon.
	Living room icon.
	Kitchen icon.
	Bedroom icon.
	Study icon.
	Cellar icon.

7 Commissioning

7.1 Commissioning procedure



Warning

- Commissioning must be done by a qualified installer.
- If adapting to another gas type, the gas valve unit must be adjusted before switching on the boiler.

1. Open the main gas valve.
2. Open the appliance gas valve.
3. Switch on the power with the boiler's on/off switch.
4. Configure the settings shown on the display.
⇒ The start-up program will start and cannot be interrupted.
5. Set the components (thermostats, control) so that heat is demanded.



Important

In the event of an error during the start-up, a message with the corresponding code is displayed. The meaning of the error codes can be found in the error table.

7.2 Gas settings

7.2.1 Factory setting

The factory setting of the boiler is for operation with the natural gas group G20 (H gas).

Tab.46 Gas 320 Ace - Factory settings G20 (H-gas)

Code	Display text	Description	285	355	430	500	575	650
DP003	Abs. max fan DHW	Maximum fan speed on Domestic Hot Water	5200	5500	3500	3800	4300	4100
GP007	Fan RPM Max CH	Maximum fan speed during Central Heating mode	5200	5500	3500	3800	4300	4100
GP008	Fan RPM Min	Minimum fan speed during Central Heating + Domestic Hot Water mode	1400	1550	950	1050	1100	1050
GP009	Fan RPM Start	Fan speed at appliance start	2500	2500	1300	1400	1400	1400

Tab.47 Gas 620 Ace - Factory settings G20 (H-gas)

Code	Display text	Description	570	710	860	1000	1150	1300
DP003	Abs. max fan DHW	Maximum fan speed on Domestic Hot Water	5200	5500	3500	3800	4300	4100
GP007	Fan RPM Max CH	Maximum fan speed during Central Heating mode	5200	5500	3500	3800	4300	4100
GP008	Fan RPM Min	Minimum fan speed during Central Heating + Domestic Hot Water mode	1900	1850	1300	1250	1400	1350
GP009	Fan RPM Start	Fan speed at appliance start	2500	2500	1300	1400	1500	1600

7.2.2 Adjusting to a different gas type

Warning
 Only a qualified installer may carry out the following operations.

Important
 If the boiler is adapted to another gas type, this must be stated on the sticker supplied. This sticker must be affixed next to the data plate.

Before operating with a different type of gas, carry out the following steps.

■ **Adjusting fan speed parameters for different gas types**

The factory fan speed settings can be adjusted for a different type of gas at installer level.

1. Select the tile [].
2. Press the button to confirm the selection.
3. Use the rotary knob to select code: **0012**.
4. Press the button to confirm the selection.
 ⇒ When the installer level is enabled, the status of the tile [] changes from **Off** into **On**.
5. Select the tile [].
6. Press the button to confirm the selection.
7. Use the rotary knob to select **Parameters, counters, signals**.
8. Press the button to confirm the selection.
9. Use the rotary knob to select **Adv. Parameters**.
10. Press the button to confirm the selection.
 ⇒ A list of available parameters appears.
11. Use the rotary knob to select the required parameter.
12. Press the button to confirm the selection.
 ⇒ The current value appears.
13. Use the rotary knob to change the setting.
14. Press the button to confirm the selection.

Fig.78 Installer level

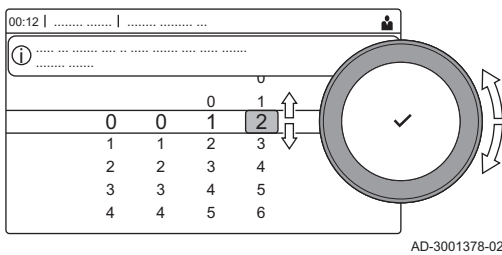

7.2.3 Fan speeds for BREEAM compliance

To comply with the BREEAM regulation, the fan speeds need to be adjusted.

For boiler Gas 620 Ace, apply the instructions to each boiler module.

1. Adjust the fan speed according to the tables below. The setting can be changed with a parameter setting.

Tab.48 Gas 320 Ace - Adjustment for BREEAM with gas type G20 (H gas)

Code	Displayed text	Description	285	355	430	500	575	650
DP003	Abs. max fan DHW	Maximum fan speed on Domestic Hot Water	5700	5800	3600	4000	4500	4300
GP007	Fan RPM Max CH	Maximum fan speed during Central Heating mode	5700	5800	3600	4000	4500	4300
GP008	Fan RPM Min	Minimum fan speed during Central Heating + Domestic Hot Water mode	1450	1500	970	1050	1100	1100
GP009	Fan RPM Start	Fan speed at appliance start	2500	2500	1300	1400	1400	1400

Tab.49 Gas 620 Ace - Adjustment for BREEAM with gas type G20 (H gas)

Code	Displayed text	Description	570	710	860	1000	1150	1300
DP003	Abs. max fan DHW	Maximum fan speed on Domestic Hot Water	5700	5800	3600	4000	4500	4300
GP007	Fan RPM Max CH	Maximum fan speed during Central Heating mode	5700	5800	3600	4000	4500	4300

Code	Displayed text	Description	570	710	860	1000	1150	1300
GP008	Fan RPM Min	Minimum fan speed during Central Heating + Domestic Hot Water mode	1900	1850	1300	1250	1400	1350
GP009	Fan RPM Start	Fan speed at appliance start	2500	2500	1300	1400	1500	1600

2. Check the setting of the gas/air ratio.

**Important**

Make sure to apply the O₂ values specified for BREEAM.

7.2.4 Checking and setting the gas/air ratio

For boiler Gas 620 Ace, apply the instructions to each boiler module. Make sure that the other boiler module is out of operation during this check and/or setting.

- The flue gas analyser must meet the requirements of BS 7927 or BS-EN 503793 and be calibrated according to the manufacturer's requirements.
- The flue gas analyser must have a minimum accuracy of $\pm 0.25\%$ O₂/CO₂.

Fig.79 Insert the probe for the flue gas analyser

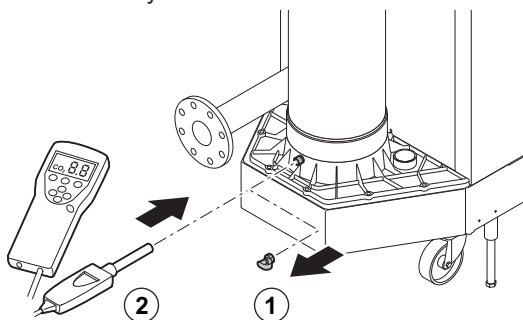

AD-3001424-01

1. Unscrew the cap from the flue gas measuring point.
2. Insert the probe for the flue gas analyser into the measurement opening.

**Warning**

Fully seal the opening around the sensor during measurement.

3. Measure the percentage of O₂/CO₂ in the flue gases. Take measurements at full load and at part load.

Fig.80 Full load test

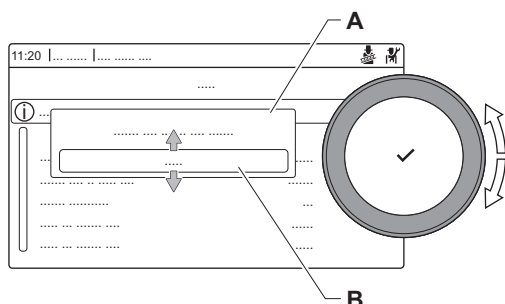

AD-3000941-03

■ Performing the full load test

1. Select the tile [🔧].
⇒ The **Change load test mode** menu appears.
2. Select the test **Medium power**.
A Change load test mode
B Medium power
⇒ The full load test starts. The selected load test mode is shown in the menu and the icon 🧑 appears in the top right of the screen.
3. Check the load test settings and adjust if necessary.
⇒ Only the parameters shown in bold can be changed.

■ Checking/setting values for O₂/CO₂ at full load

1. Set the boiler to full load.
2. Measure the percentage of O₂/CO₂ in the flue gases.
3. Compare the measured value with the checking values in the table.

Tab.50 Checking/setting values for O₂/CO₂ at full load for G20 (H gas)

Values at full load for G20 (H gas)	O ₂ (%) ⁽¹⁾	CO ₂ (%) ⁽²⁾
Gas 320 Ace 285	4.3 – 4.8 ⁽¹⁾	9.0 ⁽²⁾ – 9.3
Gas 320 Ace 355	4.3 – 4.8 ⁽¹⁾	9.0 ⁽²⁾ – 9.3
Gas 320 Ace 430	4.3 – 4.8 ⁽¹⁾	9.0 ⁽²⁾ – 9.3
Gas 320 Ace 500	4.3 – 4.8 ⁽¹⁾	9.0 ⁽²⁾ – 9.3
Gas 320 Ace 575	4.3 – 4.8 ⁽¹⁾	9.0 ⁽²⁾ – 9.3
Gas 320 Ace 650	4.3 – 4.8 ⁽¹⁾	9.0 ⁽²⁾ – 9.3
Gas 620 Ace 570	4.3 – 4.8 ⁽¹⁾	9.0 ⁽²⁾ – 9.3
Gas 620 Ace 710	4.3 – 4.8 ⁽¹⁾	9.0 ⁽²⁾ – 9.3
Gas 620 Ace 860	4.3 – 4.8 ⁽¹⁾	9.0 ⁽²⁾ – 9.3
Gas 620 Ace 1000	4.3 – 4.8 ⁽¹⁾	9.0 ⁽²⁾ – 9.3
Gas 620 Ace 1150	4.3 – 4.8 ⁽¹⁾	9.0 ⁽²⁾ – 9.3
Gas 620 Ace 1300	4.3 – 4.8 ⁽¹⁾	9.0 ⁽²⁾ – 9.3
(1) Nominal value (2) Nominal value		

Tab.51 Checking/setting values for O₂/CO₂ at full load for BREEAM with G20 (H gas)

Values at full load for BREEAM with G20 (H gas)	O ₂ (%) ⁽¹⁾⁽²⁾	CO ₂ (%) ⁽³⁾⁽⁴⁾
Gas 320 Ace 285	6.0 – 6.5 ⁽¹⁾	8.1 ⁽³⁾ – 8.4
Gas 320 Ace 355	6.0 – 6.5 ⁽¹⁾	8.1 ⁽³⁾ – 8.4
Gas 320 Ace 430	6.0 – 6.5 ⁽¹⁾	8.1 ⁽³⁾ – 8.4
Gas 320 Ace 500	6.0 – 6.5 ⁽¹⁾	8.1 ⁽³⁾ – 8.4
Gas 320 Ace 575	6.1 – 6.6 ⁽¹⁾	8.0 ⁽³⁾ – 8.3
Gas 320 Ace 650	6.1 – 6.6 ⁽¹⁾	8.0 ⁽³⁾ – 8.3
Gas 620 Ace 570	6.0 – 6.5 ⁽¹⁾	8.1 ⁽³⁾ – 8.4
Gas 620 Ace 710	6.0 – 6.5 ⁽¹⁾	8.1 ⁽³⁾ – 8.4
Gas 620 Ace 860	6.0 – 6.5 ⁽¹⁾	8.1 ⁽³⁾ – 8.4
Gas 620 Ace 1000	6.0 – 6.5 ⁽¹⁾	8.1 ⁽³⁾ – 8.4
Gas 620 Ace 1150	6.1 – 6.6 ⁽¹⁾	8.0 ⁽³⁾ – 8.3
Gas 620 Ace 1300	6.1 – 6.6 ⁽¹⁾	8.0 ⁽³⁾ – 8.3
(1) Nominal value (2) These values are only applicable when the fan speeds have been set for BREEAM. (3) Nominal value (4) These values are only applicable when the fan speeds have been set for BREEAM.		

4. If the measured value is outside of the values given in the table, correct the gas/air ratio.

Fig.81 Adjusting screw A

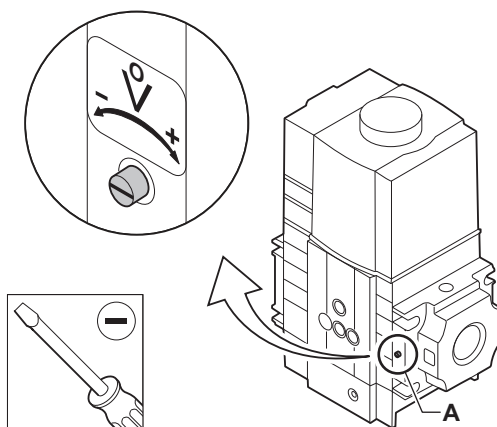
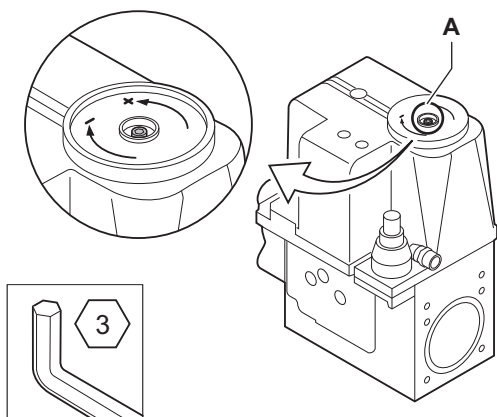

AD-0000492-01

- Use the adjustment screw **A** to set the percentage of O_2/CO_2 for the gas type being used to the nominal value. Increasing the gas flow, will decrease O_2 and increase CO_2 . The direction in which the adjusting screw must be turned to increase or decrease the gas flow is indicated on the gas control valve. The 5- to 9-section boilers are supplied with a different gas control valve from the 10-section boiler. See drawing for the position of adjusting screw **A** for full load.
- Check the flame through the inspection glass. The flame must not blow off.

Fig.82 Low load test

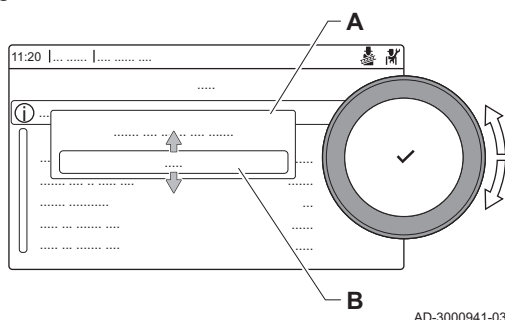

AD-3000941-03

■ Performing the low load test

- If the full load test is still running, press the ✓ button to change the load test mode.
- If the full load test was finished, select the tile [👤] to restart the chimney sweep menu.

A Change load test mode

B Low power

- Select the **Low power** test in the menu **Change load test mode**.
⇒ The low load test starts. The selected load test mode is shown in the menu and the icon 👤 appears in the top right of the screen.
- Check the load test settings and adjust if necessary.
⇒ Only the parameters shown in bold can be changed.
- End the low load test by pressing the 🔄 button.
⇒ The message **Running load test(s) stopped!** is displayed.

■ Checking/setting values for O_2/CO_2 at low load

- Set the boiler to low load.
- Measure the percentage of O_2/CO_2 in the flue gases.
- Compare the measured value with the checking values in the table.

Tab.52 Checking/setting values for O_2/CO_2 at low load for G20 (H gas)

Values at low load for G20 (H gas)	O_2 (%) ⁽¹⁾	CO_2 (%) ⁽²⁾
Gas 320 Ace 285	4.8 ⁽¹⁾ – 5.4	8.7 – 9.0 ⁽²⁾
Gas 320 Ace 355	4.8 ⁽¹⁾ – 5.4	8.7 – 9.0 ⁽²⁾
Gas 320 Ace 430	4.8 ⁽¹⁾ – 5.4	8.7 – 9.0 ⁽²⁾
Gas 320 Ace 500	4.8 ⁽¹⁾ – 5.4	8.7 – 9.0 ⁽²⁾

Values at low load for G20 (H gas)	O ₂ (%) ⁽¹⁾	CO ₂ (%) ⁽²⁾
Gas 320 Ace 575	4.8 ⁽¹⁾ – 5.4	8.7 – 9.0 ⁽²⁾
Gas 320 Ace 650	4.8 ⁽¹⁾ – 5.4	8.7 – 9.0 ⁽²⁾
Gas 620 Ace 570	4.8 ⁽¹⁾ – 5.4	8.7 – 9.0 ⁽²⁾
Gas 620 Ace 710	4.8 ⁽¹⁾ – 5.4	8.7 – 9.0 ⁽²⁾
Gas 620 Ace 860	4.8 ⁽¹⁾ – 5.4	8.7 – 9.0 ⁽²⁾
Gas 620 Ace 1000	4.8 ⁽¹⁾ – 5.4	8.7 – 9.0 ⁽²⁾
Gas 620 Ace 1150	4.8 ⁽¹⁾ – 5.4	8.7 – 9.0 ⁽²⁾
Gas 620 Ace 1300	4.8 ⁽¹⁾ – 5.4	8.7 – 9.0 ⁽²⁾
(1) Nominal value		
(2) Nominal value		

Tab.53 Checking/setting values for O₂/CO₂ at low load for BREEAM with G20 (H gas)

Values at low load for BREEAM with G20 (H gas)	O ₂ (%) ⁽¹⁾⁽²⁾	CO ₂ (%) ⁽³⁾⁽⁴⁾
Gas 320 Ace 285	6.5 ⁽¹⁾ – 7.1	7.8 – 8.1 ⁽³⁾
Gas 320 Ace 355	6.5 ⁽¹⁾ – 7.1	7.8 – 8.1 ⁽³⁾
Gas 320 Ace 430	6.5 ⁽¹⁾ – 7.1	7.8 – 8.1 ⁽³⁾
Gas 320 Ace 500	6.5 ⁽¹⁾ – 7.1	7.8 – 8.1 ⁽³⁾
Gas 320 Ace 575	6.6 ⁽¹⁾ – 7.2	7.7 – 8.0 ⁽³⁾
Gas 320 Ace 650	6.6 ⁽¹⁾ – 7.2	7.7 – 8.0 ⁽³⁾
Gas 620 Ace 570	6.5 ⁽¹⁾ – 7.1	7.8 – 8.1 ⁽³⁾
Gas 620 Ace 710	6.5 ⁽¹⁾ – 7.1	7.8 – 8.1 ⁽³⁾
Gas 620 Ace 860	6.5 ⁽¹⁾ – 7.1	7.8 – 8.1 ⁽³⁾
Gas 620 Ace 1000	6.5 ⁽¹⁾ – 7.1	7.8 – 8.1 ⁽³⁾
Gas 620 Ace 1150	6.6 ⁽¹⁾ – 7.2	7.7 – 8.0 ⁽³⁾
Gas 620 Ace 1300	6.6 ⁽¹⁾ – 7.2	7.7 – 8.0 ⁽³⁾
(1) Nominal value		
(2) These values are only applicable when the fan speeds have been set for BREEAM.		
(3) Nominal value		
(4) These values are only applicable when the fan speeds have been set for BREEAM.		

4. If the measured value is outside of the values given in the table, correct the gas/air ratio.

Fig.83 Adjusting screw B

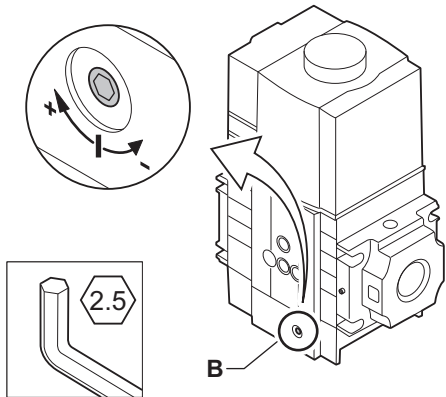
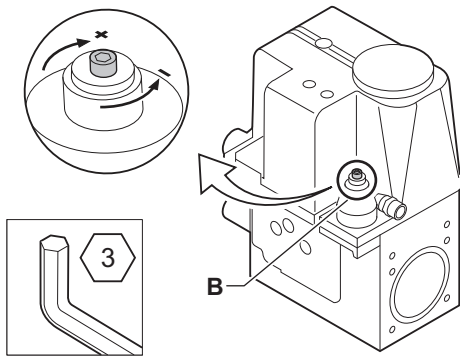

AD-0000493-01

5. Use the adjustment screw **B** to set the percentage of O₂/CO₂ for the gas type being used to the nominal value. Increasing the gas flow, will decrease O₂ and increase CO₂. The direction in which the adjusting screw must be turned to increase or decrease the gas flow is indicated on the gas control valve. The 5- to 9-section boilers are supplied with a different gas control valve from the 10-section boiler. See drawing for the position of adjusting screw **B** for low load.
6. Check the flame through the inspection glass. The flame must not blow off.
7. Repeat the full load test and the low load test as often as necessary until the correct values are obtained.
8. Set the boiler back to the normal operating status.

7.3 Final instructions

1. Remove the measuring equipment.
2. Screw the cap on to the flue gas measuring point.
3. Seal the gas valve unit.
4. Put the front casing back.
5. Heat up the central heating system to approximately 70°C.
6. Switch the boiler off.
7. Vent the central heating system after approx. 10 minutes.
8. Turn on the boiler.
9. Check the water pressure. If necessary, top up the central heating system.
10. Fill in the following data on the sticker included, and attach it next to the data plate on the appliance.
 - The gas supply pressure;
 - The flue type, if set to overpressure application;
 - The parameters modified for the changes mentioned above;
 - Any fan speed parameters modified for other purposes.
11. Complete the commissioning form, which can be found in annex.
12. Optimise the settings as required for the system and user preferences.

Fig.84 Example filled-in sticker

<p>Adjusted for / Réglée pour / Ingesteld op / Eingestellt auf / Regolato per / Ajustado para / Ρυθμιζόμενο για / Nastawiony na / настроен для / Reglat pentru / настроен за / ayarlanmıştir / Nastavljjen za / beállitva/ Nastaveno pro / Asetettu kaasulle / Justert for/ indstillet til/ ل تطبخض :</p> <p><input checked="" type="checkbox"/> Gas <u>G20</u></p> <p><u>20</u> mbar</p> <p><input checked="" type="checkbox"/> C_{(10)3(X)}</p> <p><input type="checkbox"/> C_{(12)3(X)}</p> <p><input type="checkbox"/></p>	<p>Parameters / Paramètres / Parameter / Parametri / Parámetros / Παράμετροι / Parametry / Параметри / Parametrii / Параметри / Parametreler / Paraméterek / Parametrit / Parametere / Parametre / شامل عمل :</p> <p><u>DP003 - 3300</u></p> <p><u>GP007 - 3300</u></p> <p><u>GP008 - 2150</u></p> <p><u>GP009 -</u></p>
---	--

AD-3001124-01



See

For more information; Settings, page 57 and User instructions, page 84.

13. Save the commissioning settings on the control panel, so they can be restored after a reset.
14. Instruct the user in the operation of the system, boiler and controller.
15. Inform the user of the maintenance to be performed.
16. Hand over all manuals to the user.
17. Confirm the commissioning with a signature and a company stamp.
 ⇒ The boiler is now ready for operation.

7.3.1 Saving the commissioning settings

You can save all current settings on the control panel. These settings can be restored if necessary, for example after replacement of the control unit.

1. Press the ☰ button.
2. Use the rotary knob to select **Advanced Service Menu**.
3. Press the ✓ button to confirm the selection.
4. Use the rotary knob to select **Save as commissioning settings**.
5. Press the ✓ button to confirm the selection.
6. Select **Confirm** to save the settings.

When you have saved the commissioning settings, the option **Revert commissioning settings** becomes available in the **Advanced Service Menu**.

8 Settings

8.1 Introduction to parameter codes

Fig.85 Code on a HMI T-control

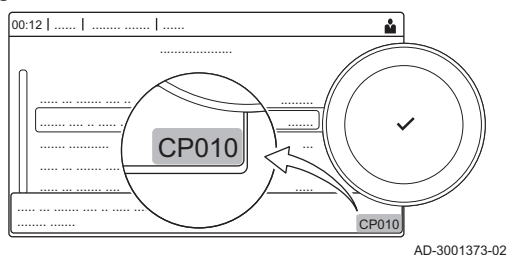

The controls platform makes use of an advanced system to categorise parameters, measurements and counters. Knowing the logic behind these codes, makes it easier to identify them. The code consists of two letters and three numbers.

Fig.86 First letter

CP010

AD-3001375-01

The first letter is the category the code relates to.

- A** Appliance: Appliance
- C** Circuit: Zone
- D** Domestic hot water: Domestic hot water
- E** External: External options
- G** Gas fired: Gas-fired heat engine
- P** Producer: Central heating

Category D codes are appliance controlled only. When the domestic hot water is controlled by an SCB, it is handled like a circuit, with C-category codes.

Fig.87 Second letter

CP010

AD-3001376-01

The second letter is the type.

- P** Parameter: Parameters
- C** Counter: Counters
- M** Measurement: Signals

Fig.88 Number

CP010

AD-3001377-01

The number is always three digits. In certain cases, the last of the three digits relates to a zone.

8.2 Accessing the installer level

Fig.89 Installer level

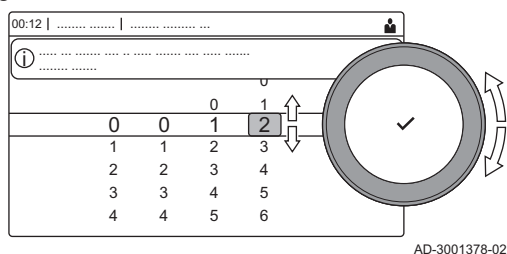

Some parameters that may affect the operation of the boiler are protected by an access code. Only the installer is allowed to modify these parameters.





1. Select the tile [].
2. Press the button to confirm the selection.
3. Use the rotary knob to select code: **0012**.
4. Press the button to confirm the selection.
 - ⇒ When the installer level is enabled, the status of the tile [] changes from **Off** into **On**.
5. To leave the installer level, select the tile [].
6. Use the rotary knob to select **Confirm** or **Cancel**.
7. Press the button to confirm the selection.
 - ⇒ When the installer level is disabled, the status of the tile [] changes from **On** into **Off**.

When the control panel is not used for 30 minutes, the installer level is left automatically.

8.2.1 Configuring the installation at installer level

Configure the installation by pressing the button and selecting **Installation Setup** . Select the control unit or circuit board you want to configure:

Tab.54 CU-GH13









Icon	Zone or function	Description
	Internal DHW (Internal DHW)	Domestic hot water produced by boiler
	CIRCA / CH	Central heating circuit
	Commercial boiler	Gas boiler
	Gas fired appliance	Gas boiler

Tab.55 Configuring a zone or function of CU-GH13 or SCB-02

Parameters, counters, signals	Description
Parameters	Set the parameters at installer level
Counters	Read the counters at installer level
Signals	Read the signals at installer level
Adv. Parameters	Set the parameters at advanced installer level
Adv. Counters	Read the counters at advanced installer level
Adv. Signals	Read the signals at advanced installer level

8.2.2 Establishing a Bluetooth connection

Proceed as follows to establish a Bluetooth connection:

1. Enable Bluetooth on the appliance:
 - 1.1. Press the  button.
 - 1.2. Use the rotary knob to select **Installation Setup**.
 - 1.3. Press the  button to confirm the selection.
 - 1.4. Use the rotary knob to select **GTW-Bluetooth > Bluetooth**.
 - 1.5. Press the  button to confirm the selection.
 - 1.6. Use the rotary knob to select **Parameters**.
 - 1.7. Press the  button to confirm the selection.
 - 1.8. Use the rotary knob to select the parameter **AP129 (Bluetooth)**.
 - 1.9. Press the  button to confirm the selection.
⇒ The current value appears.
 - 1.10. Use the rotary knob to change the setting to **1 = On**.
 - 1.11. Press the  button to confirm the selection.
2. Find the pairing code:
 - 2.1. Press the  button.
 - 2.2. Use the rotary knob to select **Installation Setup**.
 - 2.3. Press the  button to confirm the selection.
 - 2.4. Use the rotary knob to select **GTW-Bluetooth > Bluetooth**.
 - 2.5. Press the  button to confirm the selection.
 - 2.6. Use the rotary knob to select **Signals**.
 - 2.7. The pairing code is shown behind **Current pairing code**.
3. Connect to the appliance with a mobile device:
 - 3.1. On the mobile device, connect to device "**CU-GH13 + GTW-Bluetooth**".
 - 3.2. Use the pairing code from step 2.

8.3 List of parameters

8.3.1 CU-GH13 control unit settings - Gas 320 Ace

All tables show the factory setting for the parameters.



Important

The tables also list parameters that are only applicable if the boiler is combined with other equipment.

Tab.56 Navigation for basic installer level

Level	Menu path
Basic installer	☰ > Installation Setup > CU-GH > Submenu ⁽¹⁾ > Parameters, counters, signals > Parameters
(1) See the column "Submenu" in the following table for the correct navigation. The parameters are grouped in specific functionalities.	

Tab.57 Factory settings at basic installer level

Code	Display text	Description	Adjustment range	Submenu	285	355	430	500	575	650
AP016	CH function on	Enable central heating heat demand processing	0 = Off 1 = On	Gas fired appliance	1	1	1	1	1	1
AP017	DHW function on	Enable domestic hot water heat demand processing	0 = Off 1 = On	Gas fired appliance	1	1	1	1	1	1
AP074	Force summer mode	The heating is stopped. Hot water is maintained. Force Summer Mode	0 = Off 1 = On	Outdoor temperature	0	0	0	0	0	0
CP000	MaxZoneT-FlowSetpoint	Maximum Flow Temperature setpoint zone	7 - 100 °C	Direct zone	80	80	80	80	80	80
CP010	Tflow setpoint zone	Zone flow temperature setpoint, used when the zone is set to a fixed flow setpoint.	7 - 100 °C	Direct zone	90	90	90	90	90	90
CP080	User T.Room Activity	Room setpoint temperature of the user zone activity	5 - 30 °C	Direct zone	16	16	16	16	16	16
CP081	User T.Room Activity	Room setpoint temperature of the user zone activity	5 - 30 °C	Direct zone	16	16	16	16	16	16
CP082	User T.Room Activity	Room setpoint temperature of the user zone activity	5 - 30 °C	Direct zone	16	16	16	16	16	16
CP083	User T.Room Activity	Room setpoint temperature of the user zone activity	5 - 30 °C	Direct zone	16	16	16	16	16	16
CP084	User T.Room Activity	Room setpoint temperature of the user zone activity	5 - 30 °C	Direct zone	16	16	16	16	16	16
CP085	User T.Room Activity	Room setpoint temperature of the user zone activity	5 - 30 °C	Direct zone	16	16	16	16	16	16
CP200	Manu ZoneRoom-TempSet	Manually setting the room temperature setpoint of the zone	5 - 30 °C	Direct zone	20	20	20	20	20	20
CP320	Operating-ZoneMode	Operating mode of the zone	0 = Scheduling 1 = Manual 2 = Antifrost 3 = Temporary	Direct zone	0	0	0	0	0	0
CP510	Temporary Room Setp	Temporary room setpoint per zone	5 - 30 °C	Direct zone	20	20	20	20	20	20
CP550	Zone, fire place	Fire Place mode is active	0 = Off 1 = On	Direct zone	0	0	0	0	0	0
CP570	ZoneTime-Prog Select	Time Program of the zone selected by the user	0 = Schedule 1 1 = Schedule 2 2 = Schedule 3 3 = Cooling	Direct zone	0	0	0	0	0	0

Code	Display text	Description	Adjustment range	Submenu	285	355	430	500	575	650
CP660	Icon display zone	Choice icon to display this zone	0 = None 1 = All 2 = Bedroom 3 = Livingroom 4 = Study 5 = Outdoor 6 = Kitchen 7 = Basement 8 = Swimming Pool 9 = DHW Tank 10 = DHW Electrical Tank 11 = DHW Layered Tank 12 = Internal Boiler Tank 13 = Time Program	Direct zone	0	0	0	0	0	0
CP750	MaxZone Preheat time	Maximum zone preheat time	0 - 240 Min	Direct zone	0	0	0	0	0	0

Tab.58 Navigation for installer level

Level	Menu path
Installer	☰ > Installation Setup > CU-GH > Submenu ⁽¹⁾ > Parameters, counters, signals > Parameters
(1) See the column "Submenu" in the following table for the correct navigation. The parameters are grouped in specific functionalities.	

Tab.59 Factory settings at installer level

Code	Display text	Description	Adjustment range	Submenu	285	355	430	500	575	650
AP001	BL function	BL input function selection	1 = Full blocking 2 = Partial blocking 3 = User reset locking 4 = Backup relieved 5 = Generator relieved 6 = Gen.&Backup relieved 7 = High, Low Tariff 8 = Photovoltaic HP Only 9 = PV HP And backup 10 = Smart Grid ready 11 = Heating Cooling	Gas fired appliance	1	1	1	1	1	1
AP006	Min. water pressure	Appliance will report low water pressure below this value	0 - 6 bar	Gas fired appliance	0.8	0.8	0.8	0.8	0.8	0.8
AP008	Release wait time	Waiting time after closing the release contact to start the heat generator.	0 - 255 Sec	Gas fired appliance	0	0	0	0	0	0
AP009	Service hours	Number of heat generator operating hours for raising a service notification	100 - 25500 Hours	Gas fired appliance	2550 0	2550 0	2550 0	2550 0	2550 0	2550 0

Code	Display text	Description	Adjustment range	Submenu	285	355	430	500	575	650
AP010	Service notification	Select the type of service notification	0 = None 1 = Custom notification 2 = ABC notification	Gas fired appliance	0	0	0	0	0	0
AP011	Service hours mains	Hours powered to raise a service notification	100 - 25500 Hours	Gas fired appliance	8750	8750	8750	8750	8750	8750
AP056	Outdoor sensor	Enable outdoor sensor	0 = No outside sensor 1 = AF60 2 = QAC34	Outdoor temperature	0	0	0	0	0	0
AP063	Max CH flow setpoint	Maximum central heating flow temperature setpoint	20 - 90 °C	Producer Generic Gas fired appliance	90	90	90	90	90	90
AP073	Summer Winter	Outdoor temperature: upper limit for heating	15 - 30.5 °C	Outdoor temperature	22	22	22	22	22	22
AP079	Building Inertia	Inertia of the building used for heat up speed	0 - 10	Outdoor temperature	3	3	3	3	3	3
AP080	Frost min out temp	Outside temperature below which the antifreeze protection is activated	-30 - 20 °C	Outdoor temperature	-10	-10	-10	-10	-10	-10
AP091	Outside Sens. Source	Type of outside sensor connection to be used	0 = Auto 1 = Wired sensor 2 = Wireless sensor 3 = Internet measured 4 = None	Outdoor temperature	0	0	0	0	0	0
AP098	BL1 contact config.	BL1 input contact configuration	0 = Open 1 = Closed 2 = Off	Gas fired appliance	1	1	1	1	1	1
CP000	MaxZoneT-FlowSetpoint	Maximum Flow Temperature setpoint zone	7 - 100 °C	Direct zone	80	80	80	80	80	80
CP020	Zone Function	Functionality of the zone	0 = Disable 1 = Direct 2 = Mixing Circuit 3 = Swimming pool 4 = High Temperature 5 = Fan Convector 6 = DHW tank 7 = Electrical DHW 8 = Time Program 9 = ProcessHeat 10 = DHW Layered 11 = DHW Internal tank 12 = DHW Commercial Tank 13 = DHW FWS 31 = DHW FWS EXT 200 = BSB 254 = Occupied	Zone manager Zone disabled Direct zone	1	1	1	1	1	1

Code	Display text	Description	Adjustment range	Subme- nu	285	355	430	500	575	650
CP040	Postrun zone pump	Pump post runtime of the zone	0 - 20 Min	Direct zone	0	0	0	0	0	0
CP060	RoomT. Holiday	Wished room zone tem- perature on holiday period	5 - 20 °C	Direct zone	6	6	6	6	6	6
CP070	MaxRedu- ce- dRoomT.Li m	Max Room Temperature limit of the circuit in re- duced mode, that allows switching to comfort mode	5 - 30 °C	Direct zone	16	16	16	16	16	16
CP210	Zone HCZP Comfort	Comfort footpoint of the temperature of heat curve of the circuit	15 - 90 °C	Direct zone	15	15	15	15	15	15
CP220	Zone HCZP Reduced	Reduced footpoint of the temperature of heat curve of the circuit	15 - 90 °C	Direct zone	15	15	15	15	15	15
CP230	Zone Heat- ing Curve	Heating curve temperature gradient of the zone	0 - 4	Direct zone	1.5	1.5	1.5	1.5	1.5	1.5
CP240	ZoneRoom UnitInfl	Adjustment of the influ- ence of the zone room unit	0 - 10	Direct zone	3	3	3	3	3	3
CP250	CalSon- deAmbZone	Calibration of Zone Room Unit	-5 - 5 °C	Direct zone	0	0	0	0	0	0
CP340	TypeRedu- cedNight- Mode	Type of reduced night mode, stop or maintain heating of circuit	0 = Stop heat de- mand 1 = Continue heat demand	Direct zone	0	0	0	0	0	0
CP470	Zone screed drying	Setting of the screed dry- ing program of the zone	0 - 30 Days	Direct zone	0	0	0	0	0	0
CP480	ScreedStart- Temp	Setting of the start temper- ature of the screed drying program of the zone	20 - 50 °C	Direct zone	20	20	20	20	20	20
CP490	ScreedStop- Temp	Setting of the stop temper- ature of the screed drying program of the zone	20 - 50 °C	Direct zone	20	20	20	20	20	20
CP640	OTH Logi- cLev con- tact	Opentherm Logic level contact of the zone	0 = Open 1 = Closed 2 = Off	Direct zone	1	1	1	1	1	1
CP730	Zone Heat up speed	Selection of heat up speed of the zone	0 = Extra Slow 1 = Slowest 2 = Slower 3 = Normal 4 = Faster 5 = Fastest	Direct zone	0	0	0	0	0	0
CP740	Zone cool down speed	Selection of cool down speed of the zone	0 = Slowest 1 = Slower 2 = Normal 3 = Faster 4 = Fastest	Direct zone	0	0	0	0	0	0
CP780	Control strategy	Selection of the control strategy for the zone	0 = Automatic 1 = Room Temp. based 2 = Outdoor Temp. based 3 = Outdoor & room based	Direct zone	0	0	0	0	0	0
EP014	SCB func. 10V PWMin	Smart Control Board func- tion 10 Volt PWM input	0 = Off 1 = Temperature control 2 = Power control	0-10 volt input	0	0	0	0	0	0
GP007	Fan RPM Max CH	Maximum fan speed dur- ing Central Heating mode	1000 - 8500 Rpm	Gas fired ap- pliance	5200	5500	3500	3800	4300	4100

Code	Display text	Description	Adjustment range	Submenu	285	355	430	500	575	650
GP008	Fan RPM Min	Minimum fan speed during Central Heating + Domestic Hot Water mode	900 - 8500 Rpm	Gas fired appliance GVC Pneumatic	1400	1550	950	1050	1100	1050
GP009	Fan RPM Start	Fan speed at appliance start	900 - 5000 Rpm	Gas fired appliance GVC Pneumatic	2500	2500	1300	1400	1400	1400
GP010	GPS Check	Gas Pressure Switch check on/off	0 = No 1 = Yes	Gas fired appliance	1	1	1	1	1	1
GP021	Temp diff Modulating	Modulate back when delta temperature is large then this threshold	5 - 25 °C	Gas fired appliance	25	25	25	25	25	25
PP015	CH Pump postrun time	Central heating pump post run time	1 - 99 Min	Gas fired appliance	3	3	3	3	3	3
PP016	Max. CH pump speed	Maximum central heating pump speed (%)	20 - 100 %	Gas fired appliance	100	100	100	100	100	100
PP018	Min CH pump speed	Minimum central heating pump speed (%)	20 - 100 %	Gas fired appliance	20	20	20	20	20	20
PP023	CH Hysteresis	Temperature hysteresis for the generator to start on central heating	1 - 25 °C	Gas fired appliance	10	10	10	10	10	10

Tab.60 Navigation for advanced installer level

Level	Menu path
Advanced installer	≡ > Installation Setup > CU-GH > Submenu ⁽¹⁾ > Parameters, counters, signals > Adv. Parameters
(1) See the column "Submenu" in the following table for the correct navigation. The parameters are grouped in specific functionalities.	

Tab.61 Factory settings at advanced installer level

Code	Display text	Description	Adjustment range	Submenu	285	355	430	500	575	650
AP002	Manual Heat Demand	Enable manual heat demand function	0 = Off 1 = With setpoint 2 = TOutdoor Control	Gas fired appliance	0	0	0	0	0	0
AP004	Hydr Valve Wait Time	Heat generator wait time to open the hydraulic valve	0 - 255 Sec	Gas fired appliance	0	0	0	0	0	0
AP026	Setpoint manual HD	Flow temperature setpoint for manual heat demand	7 - 90 °C	Gas fired appliance	40	40	40	40	40	40
AP063	Max CH flow setpoint	Maximum central heating flow temperature setpoint	20 - 90 °C	Producer Generic Gas fired appliance	90	90	90	90	90	90

Code	Display text	Description	Adjustment range	Submenu	285	355	430	500	575	650
AP102	Boiler Pump function	Configuration of the boiler pump as zone pump or system pump (feed low-loss header)	0 = No 1 = Yes	Gas fired appliance	0	0	0	0	0	0
CP010	Tflow setpoint zone	Zone flow temperature setpoint, used when the zone is set to a fixed flow setpoint.	7 - 100 °C	Direct zone	90	90	90	90	90	90
CP290	ConfigZone-PumpOut	Configuration of Zone Pump Output	0 = Zone output 1 = CH mode 2 = DHW mode 3 = Cooling mode 4 = Error report 5 = Burning 6 = Service flag 7 = System error 8 = DHW looping 9 = Primary pump 10 = Buffer pump	Zone disabled Direct zone	0	0	0	0	0	0
CP520	Zone Power setpoint	Power setpoint per zone	0 - 100 %	Direct zone	100	100	100	100	100	100
CP530	Zone PWM Pump speed	Pulse Width Modulation pump speed per zone	20 - 100 %	Direct zone	100	100	100	100	100	100
CP680	ConfPairing RU Zone	Select the Bus channel of the room unit for this zone	0 - 255	Direct zone	0	0	0	0	0	0
DP003	Abs. max fan DHW	Maximum fan speed on Domestic Hot Water	1000 - 7000 Rpm	Gas fired appliance	5200	5500	3500	3800	4300	4100
DP010	Hysteresis DHW	Temperature hysteresis for the heat generator to start on domestic hot water production	1 - 10 °C	Gas fired appliance	5.5	5.5	5.5	5.5	5.5	5.5
DP011	Stop offset DHW	Temperature offset to stop heat generator on domestic hot water production	0 - 100 °C	Gas fired appliance	5	5	5	5	5	5
DP020	Postrun DHW pump/3wv	Post run time of the DHW pump/3 way valve after DHW production	0 - 99 Sec	Gas fired appliance	10	10	10	10	10	10
DP140	DHW load type	DHW load type (0 : Combi, 1 : Solo)	0 = Combi 1 = Solo 2 = Layered cylinder 3 = Process heat 4 = External	Gas fired appliance	1	1	1	1	1	1
GP010	GPS Check	Gas Pressure Switch check on/off	0 = No 1 = Yes	Gas fired appliance	1	1	1	1	1	1
GP017	Max power	Maximum power percentage in kilo Watt	0 - 1000 kW	Gas fired appliance	293.9	353.1	427.1	496.2	565.9	642
GP022	Tfa Filter Tau	Tau factor for average flow temperature calculation	0 - 255	Gas fired appliance	1	1	1	1	1	1
GP042	Fan RPM Max	Maximum fan speed	0 - 65535 Rpm	GVC Pneumatic	5700	5800	3700	4000	4500	4300
GP050	Power Min	Minimum power in kilo Watt for RT2012 calculation	0 - 300 kW	Gas fired appliance	54	68	82	95	109	122

Code	Display text	Description	Adjustment range	Submenu	285	355	430	500	575	650
PP007	Min anti-cycle time	Minimum heat generator holding time that can be reached after a stop	1 - 20 Min	Gas fired appliance	3	3	3	3	3	3
PP012	Stabilization time	Stabilization time after heat generator start for central heating	0 - 180 Sec	Gas fired appliance	30	30	30	30	30	30

8.3.2 CU-GH13 control unit settings - Gas 620 Ace

All tables show the factory setting for the parameters.



Important

The tables also list parameters that are only applicable if the boiler is combined with other equipment.

Tab.62 Navigation for basic installer level

Level	Menu path
Basic installer	☰ > Installation Setup > CU-GH > Submenu ⁽¹⁾ > Parameters, counters, signals > Parameters
(1) See the column "Submenu" in the following table for the correct navigation. The parameters are grouped in specific functionalities.	

Tab.63 Factory settings at basic installer level

Code	Display text	Description	Adjustment range	Submenu	570	710	860	1000	1150	1300
AP016	CH function on	Enable central heating heat demand processing	0 = Off 1 = On	Gas fired appliance	1	1	1	1	1	1
AP017	DHW function on	Enable domestic hot water heat demand processing	0 = Off 1 = On	Gas fired appliance	1	1	1	1	1	1
AP074	Force summer mode	The heating is stopped. Hot water is maintained. Force Summer Mode	0 = Off 1 = On	Outdoor temperature	0	0	0	0	0	0
CP000	MaxZoneT-FlowSet-point	Maximum Flow Temperature setpoint zone	7 - 100 °C	Direct zone	80	80	80	80	80	80
CP010	Tflow set-point zone	Zone flow temperature setpoint, used when the zone is set to a fixed flow setpoint.	7 - 100 °C	Direct zone	90	90	90	90	90	90
CP080	User T.Room Activity	Room setpoint temperature of the user zone activity	5 - 30 °C	Direct zone	16	16	16	16	16	16
CP081	User T.Room Activity	Room setpoint temperature of the user zone activity	5 - 30 °C	Direct zone	16	16	16	16	16	16
CP082	User T.Room Activity	Room setpoint temperature of the user zone activity	5 - 30 °C	Direct zone	16	16	16	16	16	16
CP083	User T.Room Activity	Room setpoint temperature of the user zone activity	5 - 30 °C	Direct zone	16	16	16	16	16	16
CP084	User T.Room Activity	Room setpoint temperature of the user zone activity	5 - 30 °C	Direct zone	16	16	16	16	16	16
CP085	User T.Room Activity	Room setpoint temperature of the user zone activity	5 - 30 °C	Direct zone	16	16	16	16	16	16

Code	Display text	Description	Adjustment range	Submenu	570	710	860	1000	1150	1300
CP200	Manu ZoneRoom-TempSet	Manually setting the room temperature setpoint of the zone	5 - 30 °C	Direct zone	20	20	20	20	20	20
CP320	Operating-ZoneMode	Operating mode of the zone	0 = Scheduling 1 = Manual 2 = Antifrost 3 = Temporary	Direct zone	0	0	0	0	0	0
CP510	Temporary Room Setp	Temporary room setpoint per zone	5 - 30 °C	Direct zone	20	20	20	20	20	20
CP550	Zone, fire place	Fire Place mode is active	0 = Off 1 = On	Direct zone	0	0	0	0	0	0
CP570	ZoneTime-Prog Select	Time Program of the zone selected by the user	0 = Schedule 1 1 = Schedule 2 2 = Schedule 3 3 = Cooling	Direct zone	0	0	0	0	0	0
CP660	Icon display zone	Choice icon to display this zone	0 = None 1 = All 2 = Bedroom 3 = Livingroom 4 = Study 5 = Outdoor 6 = Kitchen 7 = Basement 8 = Swimming Pool 9 = DHW Tank 10 = DHW Electrical Tank 11 = DHW Layered Tank 12 = Internal Boiler Tank 13 = Time Program	Direct zone	0	0	0	0	0	0
CP750	MaxZone Preheat time	Maximum zone preheat time	0 - 240 Min	Direct zone	0	0	0	0	0	0

Tab.64 Navigation for installer level

Level	Menu path
Installer	☰ > Installation Setup > CU-GH > Submenu ⁽¹⁾ > Parameters, counters, signals > Parameters
(1) See the column "Submenu" in the following table for the correct navigation. The parameters are grouped in specific functionalities.	

Tab.65 Factory settings at installer level

Code	Display text	Description	Adjustment range	Submenu	570	710	860	1000	1150	1300
AP001	BL function	BL input function selection	1 = Full blocking 2 = Partial blocking 3 = User reset locking 4 = Backup relieved 5 = Generator relieved 6 = Gen.&Backup relieved 7 = High, Low Tariff 8 = Photovoltaic HP Only 9 = PV HP And backup 10 = Smart Grid ready 11 = Heating Cooling	Gas fired appliance	1	1	1	1	1	1
AP006	Min. water pressure	Appliance will report low water pressure below this value	0 - 6 bar	Gas fired appliance	0.8	0.8	0.8	0.8	0.8	0.8
AP008	Release wait time	Waiting time after closing the release contact to start the heat generator.	0 - 255 Sec	Gas fired appliance	0	0	0	0	0	0
AP009	Service hours	Number of heat generator operating hours for raising a service notification	100 - 25500 Hours	Gas fired appliance	2550 0	2550 0	2550 0	2550 0	2550 0	2550 0
AP010	Service notification	Select the type of service notification	0 = None 1 = Custom notification 2 = ABC notification	Gas fired appliance	0	0	0	0	0	0
AP011	Service hours mains	Hours powered to raise a service notification	100 - 25500 Hours	Gas fired appliance	8750	8750	8750	8750	8750	8750
AP056	Outdoor sensor	Enable outdoor sensor	0 = No outside sensor 1 = AF60 2 = QAC34	Outdoor temperature	0	0	0	0	0	0
AP063	Max CH flow setpoint	Maximum central heating flow temperature setpoint	20 - 90 °C	Producer Generic Gas fired appliance	90	90	90	90	90	90
AP073	Summer Winter	Outdoor temperature: upper limit for heating	15 - 30.5 °C	Outdoor temperature	22	22	22	22	22	22
AP079	Building Inertia	Inertia of the building used for heat up speed	0 - 10	Outdoor temperature	3	3	3	3	3	3
AP080	Frost min out temp	Outside temperature below which the antifreeze protection is activated	-30 - 20 °C	Outdoor temperature	-10	-10	-10	-10	-10	-10

Code	Display text	Description	Adjustment range	Submenu	570	710	860	1000	1150	1300
AP091	Outside Sens. Source	Type of outside sensor connection to be used	0 = Auto 1 = Wired sensor 2 = Wireless sensor 3 = Internet measured 4 = None	Outdoor temperature	0	0	0	0	0	0
AP098	BL1 contact config.	BL1 input contact configuration	0 = Open 1 = Closed 2 = Off	Gas fired appliance	1	1	1	1	1	1
CP000	MaxZoneT-FlowSet-point	Maximum Flow Temperature setpoint zone	7 - 100 °C	Direct zone	80	80	80	80	80	80
CP020	Zone Function	Functionality of the zone	0 = Disable 1 = Direct 2 = Mixing Circuit 3 = Swimming pool 4 = High Temperature 5 = Fan Convactor 6 = DHW tank 7 = Electrical DHW 8 = Time Program 9 = ProcessHeat 10 = DHW Layered 11 = DHW Internal tank 12 = DHW Commercial Tank 13 = DHW FWS 31 = DHW FWS EXT 200 = BSB 254 = Occupied	Zone manager Zone disabled Direct zone	1	1	1	1	1	1
CP040	Postrun zone pump	Pump post runtime of the zone	0 - 20 Min	Direct zone	0	0	0	0	0	0
CP060	RoomT. Holiday	Wished room zone temperature on holiday period	5 - 20 °C	Direct zone	6	6	6	6	6	6
CP070	MaxReduce-RoomT.Lim	Max Room Temperature limit of the circuit in reduced mode, that allows switching to comfort mode	5 - 30 °C	Direct zone	16	16	16	16	16	16
CP210	Zone HCZP Comfort	Comfort footpoint of the temperature of heat curve of the circuit	15 - 90 °C	Direct zone	15	15	15	15	15	15
CP220	Zone HCZP Reduced	Reduced footpoint of the temperature of heat curve of the circuit	15 - 90 °C	Direct zone	15	15	15	15	15	15
CP230	Zone Heating Curve	Heating curve temperature gradient of the zone	0 - 4	Direct zone	1.5	1.5	1.5	1.5	1.5	1.5
CP240	ZoneRoomUnitInfl	Adjustment of the influence of the zone room unit	0 - 10	Direct zone	3	3	3	3	3	3
CP250	CalSondeAmbZone	Calibration of Zone Room Unit	-5 - 5 °C	Direct zone	0	0	0	0	0	0
CP340	TypeReducedNight-Mode	Type of reduced night mode, stop or maintain heating of circuit	0 = Stop heat demand 1 = Continue heat demand	Direct zone	0	0	0	0	0	0
CP470	Zone screed drying	Setting of the screed drying program of the zone	0 - 30 Days	Direct zone	0	0	0	0	0	0

Code	Display text	Description	Adjustment range	Submenu	570	710	860	1000	1150	1300
CP480	ScreedStart-Temp	Setting of the start temperature of the screed drying program of the zone	20 - 50 °C	Direct zone	20	20	20	20	20	20
CP490	ScreedStop-Temp	Setting of the stop temperature of the screed drying program of the zone	20 - 50 °C	Direct zone	20	20	20	20	20	20
CP640	OTH LogicLevel contact	Opentherm Logic level contact of the zone	0 = Open 1 = Closed 2 = Off	Direct zone	1	1	1	1	1	1
CP730	Zone Heat up speed	Selection of heat up speed of the zone	0 = Extra Slow 1 = Slowest 2 = Slower 3 = Normal 4 = Faster 5 = Fastest	Direct zone	0	0	0	0	0	0
CP740	Zone cool down speed	Selection of cool down speed of the zone	0 = Slowest 1 = Slower 2 = Normal 3 = Faster 4 = Fastest	Direct zone	0	0	0	0	0	0
CP780	Control strategy	Selection of the control strategy for the zone	0 = Automatic 1 = Room Temp. based 2 = Outdoor Temp. based 3 = Outdoor & room based	Direct zone	0	0	0	0	0	0
EP014	SCB func. 10V PWMIn	Smart Control Board function 10 Volt PWM input	0 = Off 1 = Temperature control 2 = Power control	0-10 volt input	0	0	0	0	0	0
GP007	Fan RPM Max CH	Maximum fan speed during Central Heating mode	1000 - 8500 Rpm	Gas fired appliance	5200	5500	3500	3800	4300	4100
GP008	Fan RPM Min	Minimum fan speed during Central Heating + Domestic Hot Water mode	900 - 8500 Rpm	Gas fired appliance GVC Pneumatic	1900	1850	1300	1250	1400	1350
GP009	Fan RPM Start	Fan speed at appliance start	900 - 5000 Rpm	Gas fired appliance GVC Pneumatic	2500	2500	1400	1400	1500	1600
GP010	GPS Check	Gas Pressure Switch check on/off	0 = No 1 = Yes	Gas fired appliance	1	1	1	1	1	1
GP021	Temp diff Modulating	Modulate back when delta temperature is large then this threshold	5 - 25 °C	Gas fired appliance	25	25	25	25	25	25
PP015	CH Pump postrun time	Central heating pump post run time	1 - 99 Min	Gas fired appliance	3	3	3	3	3	3
PP016	Max. CH pump speed	Maximum central heating pump speed (%)	20 - 100 %	Gas fired appliance	100	100	100	100	100	100

Code	Display text	Description	Adjustment range	Submenu	570	710	860	1000	1150	1300
PP018	Min CH pump speed	Minimum central heating pump speed (%)	20 - 100 %	Gas fired appliance	20	20	20	20	20	20
PP023	CH Hysteresis	Temperature hysteresis for the generator to start on central heating	1 - 25 °C	Gas fired appliance	10	10	10	10	10	10

Tab.66 Navigation for advanced installer level

Level	Menu path
Advanced installer	≡ > Installation Setup > CU-GH > Submenu ⁽¹⁾ > Parameters, counters, signals > Adv. Parameters
(1) See the column "Submenu" in the following table for the correct navigation. The parameters are grouped in specific functionalities.	

Tab.67 Factory settings at advanced installer level

Code	Display text	Description	Adjustment range	Submenu	570	710	860	1000	1150	1300
AP002	Manual Heat Demand	Enable manual heat demand function	0 = Off 1 = With setpoint 2 = TOutdoor Control	Gas fired appliance	0	0	0	0	0	0
AP004	Hydr Valve Wait Time	Heat generator wait time to open the hydraulic valve	0 - 255 Sec	Gas fired appliance	0	0	0	0	0	0
AP026	Setpoint manual HD	Flow temperature setpoint for manual heat demand	7 - 90 °C	Gas fired appliance	40	40	40	40	40	40
AP063	Max CH flow setpoint	Maximum central heating flow temperature setpoint	20 - 90 °C	Producer Generic Gas fired appliance	90	90	90	90	90	90
AP102	Boiler Pump function	Configuration of the boiler pump as zone pump or system pump (feed low-loss header)	0 = No 1 = Yes	Gas fired appliance	0	0	0	0	0	0
CP010	Tflow setpoint zone	Zone flow temperature setpoint, used when the zone is set to a fixed flow setpoint.	7 - 100 °C	Direct zone	90	90	90	90	90	90
CP290	ConfigZone-PumpOut	Configuration of Zone Pump Output	0 = Zone output 1 = CH mode 2 = DHW mode 3 = Cooling mode 4 = Error report 5 = Burning 6 = Service flag 7 = System error 8 = DHW looping 9 = Primary pump 10 = Buffer pump	Zone disabled Direct zone	0	0	0	0	0	0
CP520	Zone Power setpoint	Power setpoint per zone	0 - 100 %	Direct zone	100	100	100	100	100	100
CP530	Zone PWM Pump speed	Pulse Width Modulation pump speed per zone	20 - 100 %	Direct zone	100	100	100	100	100	100
CP680	ConfPairing RU Zone	Select the Bus channel of the room unit for this zone	0 - 255	Direct zone	0	0	0	0	0	0

Code	Display text	Description	Adjustment range	Subme- nu	570	710	860	1000	1150	1300
DP003	Abs. max fan DHW	Maximum fan speed on Domestic Hot Water	1000 - 7000 Rpm	Gas fired appliance	5200	5500	3500	3800	4300	4100
DP010	Hysteresis DHW	Temperature hysteresis for the heat generator to start on domestic hot water production	1 - 10 °C	Gas fired appliance	5.5	5.5	5.5	5.5	5.5	5.5
DP011	Stop offset DHW	Temperature offset to stop heat generator on domestic hot water production	0 - 100 °C	Gas fired appliance	5	5	5	5	5	5
DP020	Postrun DHW pump/3wv	Post run time of the DHW pump/3 way valve after DHW production	0 - 99 Sec	Gas fired appliance	10	10	10	10	10	10
DP140	DHW load type	DHW load type (0 : Combi, 1 : Solo)	0 = Combi 1 = Solo 2 = Layered cylinder 3 = Process heat 4 = External	Gas fired appliance	1	1	1	1	1	1
GP010	GPS Check	Gas Pressure Switch check on/off	0 = No 1 = Yes	Gas fired appliance	1	1	1	1	1	1
GP017	Max power	Maximum power percentage in kilo Watt	0 - 1000 kW	Gas fired appliance	294. 2	351. 2	425. 6	494. 7	564. 4	642
GP022	Tfa Filter Tau	Tau factor for average flow temperature calculation	0 - 255	Gas fired appliance	1	1	1	1	1	1
GP042	Fan RPM Max	Maximum fan speed	0 - 65535 Rpm	GVC Pneumatic	5700	5800	3700	4000	4500	4300
GP050	Power Min	Minimum power in kilo Watt for RT2012 calculation	0 - 300 kW	Gas fired appliance	80	111	142	141	170	180
PP007	Min anti-cycle time	Minimum heat generator holding time that can be reached after a stop	1 - 20 Min	Gas fired appliance	3	3	3	3	3	3
PP012	Stabilization time	Stabilization time after heat generator start for central heating	0 - 180 Sec	Gas fired appliance	30	30	30	30	30	30

9 Maintenance

9.1 Maintenance regulations



Important

The boiler must be maintained by a qualified installer in accordance with local and national regulations.

- An annual inspection is mandatory.
- Perform the standard checking and maintenance procedures once a year.
- Perform the specific maintenance procedures if necessary.



Important

Adjust the frequency of inspection and service to the conditions of use. This applies especially if the boiler is:

- In constant use (for specific processes)
- Used with a low supply temperature
- Used with a high ΔT



Caution

- Replace defective or worn parts with original spare parts. Not doing so will void warranty.
- During inspection and maintenance work, always replace all gaskets on the parts removed.
- Check whether all gaskets have been positioned properly (absolutely flat in the appropriate groove means they are gas, air and water tight).
- During the inspection and maintenance work, water (drops, splashes) must never come into contact with the electrical parts.



Warning

Always wear safety goggles and a dust mask during cleaning work (involving compressed air).



Danger of electric shock

Ensure that the boiler is switched off.

9.2 Opening the boiler

Fig.90 Removing the panels

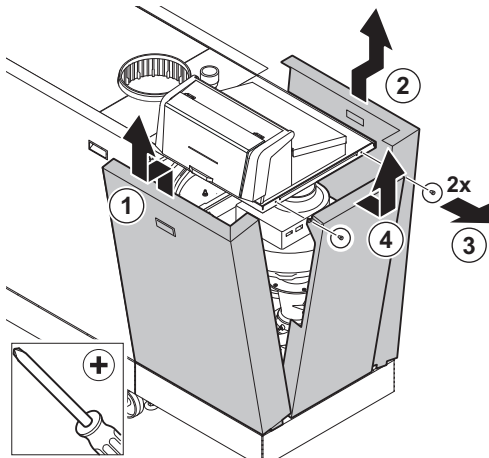

AD-3001407-02

1. Remove the panels in the given order.

9.3 Disposal and recycling

**Caution**

Only qualified professionals are permitted to remove and dispose of the boiler, in accordance with local and national regulations.

Fig.91



If you need to remove the boiler, proceed as follows:

1. Switch off the boiler.
2. Cut the power supply to the boiler.
3. Close the main gas valve.
4. Close the water mains.
5. Close the gas valve on the boiler.
6. Drain the installation.
7. Remove the air/flue gas pipes.
8. Disconnect all pipes.
9. Dismantle the boiler.

10 Troubleshooting

10.1 Error codes

The boiler is fitted with an electronic regulation and control unit. The heart of the control is a **e-Smart** microprocessor, which controls and also protects the boiler. In the event of an error, a corresponding code is displayed.

Tab.68 Error codes are displayed at three different levels

Code	Type	Description
A00.00 ⁽¹⁾	Warning	The boiler continues to operate but the cause of the warning must be investigated. A warning can change into a blocking or lock-out.
H00.00 ⁽¹⁾	Blocking	The boiler starts up again automatically when the cause of the blocking has been rectified. A blocking can become a lock-out.
E00.00 ⁽¹⁾	Lock out	The boiler starts up again only when the cause of the lock-out has been rectified and reset manually.

(1) The first letter indicates the type of error.

The meaning of the code can be found in the various error code tables.



Important

The error code is needed to find the cause of the error quickly and correctly and for any support from Remeha.

10.1.1 Display of error codes

Fig.92 HMI T-control

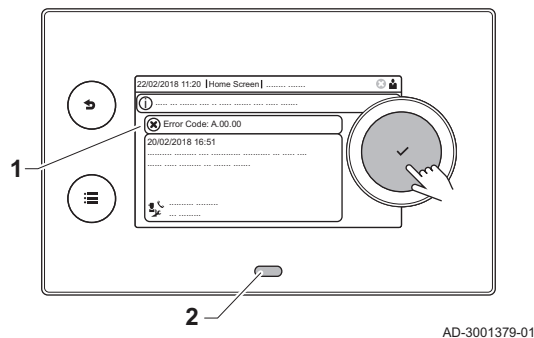

When an error occurs in the installation, the control panel shows:

- 1 The display will show a corresponding code and message.
- 2 The status LED of the control panel will show:
 - Continuous green = Normal operation
 - Flashing green = Warning
 - Continuous red = Blocking
 - Flashing red = Lock out

1. Press and hold the ✓ button to reset the boiler.
 - ⇒ The boiler starts up again only when the cause of the error has been rectified.
2. If the error code reappears, correct the problem by following the instructions in the error code tables.
 - ⇒ The error code remains visible until the problem is solved.
3. Note the error code when the problem cannot be solved.

10.1.2 Warning

Tab.69 Warning codes

Code	Display text	Description	Solution
A.00.00	TFlow Open	Flow temperature sensor is either removed or measures a temperature below range	Zone flow temperature sensor open: <ul style="list-style-type: none"> • Sensor is not present. • Bad connection: check the wiring and connectors. • Incorrectly fitted sensor: check that the sensor has been correctly fitted. • Faulty sensor: replace the sensor.
A.00.01	TFlow Closed	Flow temperature sensor is either shorted or measures a temperature above range	Zone flow temperature sensor short-circuited: <ul style="list-style-type: none"> • Sensor is not present. • Bad connection: check the wiring and connectors. • Incorrectly fitted sensor: check that the sensor has been correctly fitted. • Faulty sensor: replace the sensor.
A.01.21	Dhw Temp GradLevel3	Maximum Dhw Temperature Gradient Level3 Exceeded	Temperature warning: <ul style="list-style-type: none"> • Check the flow.
A.02.06	Water Press Warning	Water Pressure Warning active	Water pressure warning: <ul style="list-style-type: none"> • Water pressure too low; check the water pressure
A.02.37	Uncritic device lost	Uncritical device has been disconnected	SCB not found: <ul style="list-style-type: none"> • Bad connection: check the wiring and connectors • Faulty SCB: Replace SCB
A.02.45	Full Can Conn Matrix	Full Can Connection Matrix	SCB not found: <ul style="list-style-type: none"> • Carry out an auto-detect
A.02.46	Full Can Device Adm	Full Can Device Administration	SCB not found: <ul style="list-style-type: none"> • Carry out an auto-detect
A.02.49	Failed Init Node	Failed Initialising Node	SCB not found: <ul style="list-style-type: none"> • Carry out an auto-detect
A.02.55	Inval or miss SerNR	Invalid or missing device serial number	Contact your supplier.
A.03.17	Safety check	Periodically safety check ongoing	Safety check procedure active: <ul style="list-style-type: none"> • No action

10.1.3 Blocking

Tab.70 Blocking codes

Code	Display text	Description	Solution
H.00.16	DHW sensor Open	Domestic Hot Water tank temperature sensor is either removed or measures a temperature below range	Domestic hot water temperature sensor open: <ul style="list-style-type: none"> • Sensor is not present • Incorrectly fitted sensor: check that the sensor has been correctly fitted • Bad connection: check the wiring and connectors • Faulty sensor: replace the sensor
H.00.17	DHW sensor Closed	Domestic Hot Water tank temperature sensor is either shorted or measures a temperature above range	Domestic hot water temperature sensor short-circuited: <ul style="list-style-type: none"> • Incorrectly fitted sensor: check that the sensor has been correctly fitted • Bad connection: check the wiring and connectors • Faulty sensor: replace the sensor
H.00.36	T 2nd Return Open	Second return temperature sensor is either removed or measures a temperature below range	Second return temperature sensor open: <ul style="list-style-type: none"> • Bad connection: check the wiring and connectors. • Incorrectly fitted sensor: check that the sensor has been correctly fitted. • Faulty sensor: replace the sensor.
H.00.37	T 2nd Return Closed	Second return temperature sensor is either shorted or measures a temperature above range	Second return temperature sensor short-circuited: <ul style="list-style-type: none"> • Bad connection: check the wiring and connectors. • Incorrectly fitted sensor: check that the sensor has been correctly fitted. • Faulty sensor: replace the sensor.
H.01.00	Comm Error	Communication Error occurred	Communication error with the security kernel: <ul style="list-style-type: none"> • Restart the boiler • Replace the CU-GH
H.01.06	Max Delta TH-TF	Maximum difference between heat exchanger temperature and flow temperature	Maximum difference between heat exchanger and flow temperature exceeded: <ul style="list-style-type: none"> • No flow or insufficient flow: <ul style="list-style-type: none"> - Check the circulation (direction, pump, valves). - Check the water pressure. - Check the cleanliness of the heat exchanger. - Check that the installation has been de-aired. - Check water quality according to supplier's specifications. • Sensor error: <ul style="list-style-type: none"> - Check that the sensors are operating correctly. - Check that the sensor has been fitted properly.

Code	Display text	Description	Solution
H.01.07	Max Delta TH-TR	Maximum difference between heat exchanger temperature and return temperature	<p>Maximum difference between heat exchanger and return temperature exceeded:</p> <ul style="list-style-type: none"> • No flow or insufficient flow: <ul style="list-style-type: none"> - Check the circulation (direction, pump, valves). - Check the water pressure. - Check the cleanliness of the heat exchanger. - Check that the installation has been correctly vented to remove air. • Sensor error: <ul style="list-style-type: none"> - Check that the sensors are operating correctly. - Check that the sensor has been fitted properly.
H.01.08	CH Temp Grad. Level3	Maximum CH temperature gradient level3 exceeded	<p>Maximum heat exchanger temperature increase has been exceeded:</p> <ul style="list-style-type: none"> • No flow or insufficient flow: <ul style="list-style-type: none"> - Check the circulation (direction, pump, valves) - Check the water pressure - Check the cleanliness of the heat exchanger - Check that the central heating system has been correctly vented to remove air • Sensor error: <ul style="list-style-type: none"> - Check that the sensors are operating correctly - Check that the sensor has been fitted properly
H.01.09	Gas Pressure Switch	Gas Pressure Switch	<p>Gas pressure too low:</p> <ul style="list-style-type: none"> • No flow or insufficient flow: <ul style="list-style-type: none"> - Make sure that the gas valve is fully opened - Check the gas supply pressure - If a gas filter is present: Make sure that the filter is clean • Wrong setting on the gas pressure switch: <ul style="list-style-type: none"> - Make sure that the switch has been fitted properly - Replace the switch if necessary
H.01.13	Max THeat Ex	Heat Exchanger temperature has exceeded the maximum operating value	<p>Maximum heat exchanger temperature exceeded:</p> <ul style="list-style-type: none"> • Check the circulation (direction, pump, valves). • Check the water pressure. • Check that the sensors are operating correctly. • Check that the sensor has been fitted properly. • Check the cleanliness of the heat exchanger. • Check that the central heating system has been correctly vented to remove air.
H.01.14	Max Tflow	Flow temperature has exceeded the maximum operating value	<p>Flow temperature sensor above normal range:</p> <ul style="list-style-type: none"> • Bad connection: check the wiring and connectors • No flow or insufficient flow: <ul style="list-style-type: none"> - Check the circulation (direction, pump, valves) - Check the water pressure - Check the cleanliness of the heat exchanger
H.01.15	Max Tflue Gas	Flue gas temperature has exceeded the maximum operating value	<p>Maximum flue gas temperature exceeded:</p> <ul style="list-style-type: none"> • Check the flue gas outlet system • Check the heat exchanger to ensure that the flue gas side is not clogged • Faulty sensor: replace the sensor

Code	Display text	Description	Solution
H.02.00	Reset In Progress	Reset In Progress	Reset procedure active: <ul style="list-style-type: none"> • No action
H.02.02	Wait Config Number	Waiting For Configuration Number	Configuration error or unknown configuration number: <ul style="list-style-type: none"> • Reset CN1 and CN2
H.02.03	Conf Error	Configuration Error	Configuration error or unknown configuration number: <ul style="list-style-type: none"> • Reset CN1 and CN2
H.02.04	Parameter Error	Parameter Error	Factory settings incorrect: <ul style="list-style-type: none"> • Parameters are not correct: <ul style="list-style-type: none"> - Restart the boiler - Reset CN1 and CN2 - Replace the CU-GH PCB
H.02.05	CSU CU mismatch	CSU does not match CU type	Configuration error: <ul style="list-style-type: none"> • Reset CN1 and CN2
H.02.09	Partial block	Partial blocking of the device recognized	Blocking input active or frost protection active: <ul style="list-style-type: none"> • External cause: remove external cause • Wrong parameter set: check the parameters • Bad connection: check the connection
H.02.10	Full Block	Full blocking of the device recognized	Blocking input is active (without frost protection): <ul style="list-style-type: none"> • External cause: remove external cause • Wrong parameter set: check the parameters • Bad connection: check the connection
H.02.12	Release Signal	Release Signal input of the Control Unit from device external environment	Waiting time release signal has elapsed: <ul style="list-style-type: none"> • External cause: remove external cause • Wrong parameter set: check the parameters • Bad connection: check the connection
H.02.15	Ext CSU Timeout	External CSU Timeout	CSU time out: <ul style="list-style-type: none"> • Bad connection: check the wiring and connectors. • Faulty CSU: replace CSU.
H.02.18	OBD Error	Object Dictionary Error	<ul style="list-style-type: none"> • Reset CN1 and CN2  See The data plate for the CN1 and CN2 values.
H.02.36	Funct device lost	Functional device has been disconnected	Communication error with the SCB PCB: <ul style="list-style-type: none"> • Bad connection with BUS: check the wiring. • No PCB: reconnect PCB or retrieve from memory using auto-detect.
H.02.48	Funct Gr Conf Fault	Function Group Configuration Fault	SCB not found: <ul style="list-style-type: none"> • Carry out an auto-detect
H.02.50	Funct Gr Comm Err	Function Group Communication Error	SCB not found: <ul style="list-style-type: none"> • Carry out an auto-detect.
H.02.62	Unsupported function	Zone B doesn't support the selected function	Zone B function setting is not correct or is not allowed on this circuit: <ul style="list-style-type: none"> • Check the setting of parameter CP021.
H.02.64	Unsupported function	Zone D doesn't support the selected function	Zone C function (DHW) setting is not correct or is not allowed on this circuit: <ul style="list-style-type: none"> • Check the setting of parameter CP022.
H.02.80	Missing Cascade Ctrl	Missing Cascade controller	Cascade controller not found: <ul style="list-style-type: none"> • Reconnect the cascade master • Carry out an auto-detect

Code	Display text	Description	Solution
H.03.00	Parameter Error	Safety parameters level 2, 3, 4 are not correct or missing	Parameter error: security kernel <ul style="list-style-type: none"> Restart the boiler Replace the CU-GH
H.03.01	CU to GVC data error	No valid data from CU to GVC received	Communication error with the CU-GH: <ul style="list-style-type: none"> Restart the boiler
H.03.02	Flame loss detected	Measured ionisation current is below limit	No flame during operation: <ul style="list-style-type: none"> No ionisation current: <ul style="list-style-type: none"> Vent the gas supply to remove air Check that the gas valve is fully opened Check the gas supply pressure Check the operation and setting of the gas valve unit Check that the air supply inlet and flue gas outlet are not blocked Check that there is no recirculation of flue gases
H.03.05	Internal blocking	Gas Valve Control internal blocking occurred	Security kernel error: <ul style="list-style-type: none"> Restart the boiler Replace the CU-GH

10.1.4 Locking

Tab.71 Locking codes

Code	Display text	Description	Solution
E.00.00	TFlow Open	Flow temperature sensor is either removed or measures a temperature below range	Zone flow temperature sensor open: <ul style="list-style-type: none"> Sensor is not present. Bad connection: check the wiring and connectors. Incorrectly fitted sensor: check that the sensor has been correctly fitted. Faulty sensor: replace the sensor.
E.00.01	TFlow Closed	Flow temperature sensor is either shorted or measures a temperature above range	Zone flow temperature sensor short-circuited: <ul style="list-style-type: none"> Sensor is not present. Bad connection: check the wiring and connectors. Incorrectly fitted sensor: check that the sensor has been correctly fitted. Faulty sensor: replace the sensor.
E.00.04	TReturn Open	Return temperature sensor is either removed or measures a temperature below range	Return temperature sensor open: <ul style="list-style-type: none"> Bad connection: check the wiring and connectors Incorrectly fitted sensor: check that the sensor has been correctly fitted Faulty sensor: replace the sensor
E.00.05	TReturn Closed	Return temperature sensor is either shorted or measures a temperature above range	Return temperature sensor short-circuited: <ul style="list-style-type: none"> Bad connection: check the wiring and connectors Incorrectly fitted sensor: check that the sensor has been correctly fitted Faulty sensor: replace the sensor
E.00.08	THeat Ex Open	Heat exchanger temperature sensor is either removed or measures a temperature below range	Heat exchanger temperature sensor open: <ul style="list-style-type: none"> Bad connection: check the wiring and connectors. Incorrectly fitted sensor: check that the sensor has been correctly fitted. Faulty sensor: replace the sensor.

Code	Display text	Description	Solution
E.00.09	THeat Ex Closed	Heat exchanger temperature sensor is either shorted or measures a temperature above range	Heat exchanger temperature sensor short-circuited: <ul style="list-style-type: none"> • Bad connection: check the wiring and connectors. • Incorrectly fitted sensor: check that the sensor has been correctly fitted. • Faulty sensor: replace the sensor.
E.00.20	TFlue Gas Open	Flue gas temperature sensor is either removed or measures a temperature below range	Open circuit in flue gas sensor: <ul style="list-style-type: none"> • Bad connection: check the wiring and connectors. • Incorrectly fitted sensor: check that the sensor has been correctly fitted. • Faulty sensor: replace the sensor.
E.00.21	TFlue Gas Closed	Flue gas temperature sensor is either shorted or measures a temperature above range	Flue gas sensor short-circuited: <ul style="list-style-type: none"> • Bad connection: check the wiring and connectors. • Incorrectly fitted sensor: check that the sensor has been correctly fitted. • Faulty sensor: replace the sensor.
E.00.40	WaterPressureOpen	Water pressure sensor is either removed or measures a temperature below range	Hydraulic pressure sensor open: <ul style="list-style-type: none"> • Bad connection: check the wiring and connectors. • Incorrectly fitted sensor: check that the sensor has been correctly fitted. • Faulty sensor: replace the sensor.
E.00.41	WaterPressureClosed	Water pressure sensor is either shorted or measures a temperature above range	Hydraulic pressure sensor short-circuited: <ul style="list-style-type: none"> • Bad connection: check the wiring and connectors. • Incorrectly fitted sensor: check that the sensor has been correctly fitted. • Faulty sensor: replace the sensor.
E.01.04	5x Flame Loss Error	5x Error of unintended Flame Loss occurrence	Flame loss occurs 5 times: <ul style="list-style-type: none"> • Vent the gas supply to remove air • Check that the gas valve is fully opened • Check the gas supply pressure • Check the operation and setting of the gas valve unit • Check that the air supply inlet and flue gas outlet are not blocked • Check that there is no recirculation of flue gases
E.01.12	Return Higher Flow	Return temperature has a higher temperature value than the flow temperature	Flow and return reversed: <ul style="list-style-type: none"> • Bad connection: check the wiring and connectors • Water circulation in wrong direction: check the circulation (direction, pump, valves) • Incorrectly fitted sensor: check that the sensor has been correctly fitted • Malfunctioning sensor: check the Ohmic value of the sensor • Faulty sensor: replace the sensor
E.02.04	Parameter Error	Parameter Error	Configuration error: <ul style="list-style-type: none"> • Reset CN1 and CN2  See The data plate for the CN1 and CN2 values.

Code	Display text	Description	Solution
E.02.13	Blocking Input	Blocking Input of the Control Unit from device external environment	Blocking input is active: <ul style="list-style-type: none"> External cause: remove external cause Wrong parameter set: check the parameters
E.02.15	Ext CSU Timeout	External CSU Timeout	CSU time out: <ul style="list-style-type: none"> Bad connection: check the wiring and connectors Faulty CSU: Replace CSU
E.02.17	GVC CommTimeout	Gas Valve Control unit communication has exceeded feedback time	Communication error with the security kernel: <ul style="list-style-type: none"> Restart the boiler Replace the CU-GH
E.02.35	Safety device lost	Safety critical device has been disconnected	Communication fault <ul style="list-style-type: none"> Carry out an auto-detect
E.02.47	Failed Conn Funct Gr	Failed Connecting Function Groups	Function group not found: <ul style="list-style-type: none"> Carry out an auto-detect Restart the boiler Replace the CU-GH
E.02.48	Funct Gr Conf Fault	Function Group Configuration Fault	SCB not found: <ul style="list-style-type: none"> Carry out an auto-detect.
E.02.70	HRU test error	External heat recovery unit test failed	Heat recovery unit non-return valve check failed: <ul style="list-style-type: none"> Check the external heat recovery unit non-return valve.
E.04.00	Parameter error	Safety parameters Level 5 are not correct or missing	Replace the CU-GH.
E.04.01	TFlow Closed	Flow temperature sensor is either shorted or measuring a temperature above range	Flow temperature sensor short circuited: <ul style="list-style-type: none"> Bad connection: check the wiring and connectors Incorrectly fitted sensor: check that the sensor has been correctly fitted Faulty sensor: replace the sensor
E.04.02	TFlow Open	Flow temperature sensor is either removed or measuring a temperature below range	Flow temperature sensor open: <ul style="list-style-type: none"> Bad connection: check the wiring and connectors Faulty sensor: replace the sensor
E.04.03	Max Flow temp	Measured flow temperature above safety limit	No flow or insufficient flow: <ul style="list-style-type: none"> Check the circulation (direction, pump, valves) Check the water pressure Check the cleanliness of the heat exchanger
E.04.04	TFlue Closed	Flue temperature sensor is either shorted or measuring a temperature above range	Flue gas temperature sensor short-circuited: <ul style="list-style-type: none"> Bad connection: check the wiring and connectors Incorrectly fitted sensor: check that the sensor has been correctly fitted Faulty sensor: replace the sensor
E.04.05	TFlue Open	Flue temperature sensor is either removed or measuring a temperature below range	Flue gas temperature sensor open: <ul style="list-style-type: none"> Bad connection: check the wiring and connectors Incorrectly fitted sensor: check that the sensor has been correctly fitted Faulty sensor: replace the sensor
E.04.07	TFlow Sensor	Deviation in flow sensor 1 and flow sensor 2 detected	Flow temperature sensor deviation: <ul style="list-style-type: none"> Bad connection: check the connection Faulty sensor: replace the sensor

Code	Display text	Description	Solution
E.04.08	Safety input	Safety input is open	Air pressure differential switch activated: <ul style="list-style-type: none"> • Bad connection: check the wiring and connectors • Pressure in flue gas duct is or was too high: <ul style="list-style-type: none"> - Non-return valve does not open - Siphon blocked or empty - Check that the air supply inlet and flue gas outlet are not blocked - Check the cleanliness of the heat exchanger
E.04.09	TFlue Sensor	Deviation in flue sensor 1 and flue sensor 2 detected	Flue gas temperature sensor deviation: <ul style="list-style-type: none"> • Bad connection: check the connection • Faulty sensor: replace the sensor
E.04.10	Unsuccessful start	5 Unsuccessful burners starts detected	Five failed burner starts: <ul style="list-style-type: none"> • No ignition spark: <ul style="list-style-type: none"> - Check the wiring between the CU-GH and the ignition transformer - Check the ionisation/ignition electrode - Check breakdown to earth - Check the condition of the burner cover - Check the earthing - Replace the CU-GH • Ignition spark but no flame: <ul style="list-style-type: none"> - Vent the gas pipes to remove air - Check that the air supply inlet and flue gas outlet are not blocked - Check that the gas valve is fully opened - Check the gas supply pressure - Check the operation and setting of the gas valve unit - Check the wiring on the gas valve unit - Replace the CU-GH • Flame present, but ionisation has failed or is inadequate: <ul style="list-style-type: none"> - Check that the gas valve is fully opened - Check the gas supply pressure - Check the ionisation/ignition electrode - Check the earthing - Check the wiring on the ionisation/ignition electrode.
E.04.11	VPS	VPS Gas Valve proving failed	Gas leakage control fault: <ul style="list-style-type: none"> • Bad connection: check the wiring and connectors • Gas leakage control VPS faulty: Replace the valve proving system (VPS) • Gas valve unit faulty: Replace the gas valve unit
E.04.12	False flame	False flame detected before burner start	False flame signal: <ul style="list-style-type: none"> • The burner remains very hot: Set the O₂ • Ionisation current measured but no flame should be present: check the ionisation/ignition electrode • Faulty gas valve: replace the gas valve • Faulty ignition transformer: replace the ignition transformer
E.04.13	Fan	Fan speed has exceeded normal operating range	Fan fault: <ul style="list-style-type: none"> • Bad connection: check the wiring and connectors. • Fan operates when it should not be operating: check for excessive chimney draught • Faulty fan: replace the fan

Code	Display text	Description	Solution
E.04.15	FlueGas Pipe Blocked	The flue gas pipe is blocked	Flue gas outlet is blocked: <ul style="list-style-type: none"> • Check that the flue gas outlet is not blocked • Restart the boiler
E.04.17	GasValve Driver Err.	The driver for the gas valve is broken	Gas valve unit fault: <ul style="list-style-type: none"> • Bad connection: check the wiring and connectors • Faulty gas valve unit: Replace the gas valve unit
E.04.23	Internal Error	Gas Valve Control internal locking	<ul style="list-style-type: none"> • Restart the boiler • Replace the CU-GH
E.04.250	Internal error	Gas valve relay error detected	Internal error: <ul style="list-style-type: none"> • Replace the PCB.
E.04.254	Unknown	Unknown	Unknown error: <ul style="list-style-type: none"> • Replace the PCB.

10.2 Error history

The control panel includes an error memory in which is stored a history of the last 32 errors. Details of the boiler when the error occurred can be read out. For example;

- status
- sub-status
- flow temperature
- return temperature

These details and others can contribute to the error solution.

10.2.1 Reading out and clearing the error memory

The error memory stores the details of the most recent errors.









1. Select the tile [].
2. Press the  button to confirm the selection.
3. Use the rotary knob to select code: **0012**
4. Press the  button to confirm the selection.
 - ⇒ When the installer level is enabled, the status of the tile [] changes from **Off** into **On**.
5. Press the  button.
6. Use the rotary knob to select **Error History**.
7. Press the  button to confirm the selection.
 - ⇒ A list up to 32 most recent errors is displayed with the error code, a short description and the date.
8. Use the rotary knob to select the error code you want to investigate.
9. Press the  button to confirm the selection.
 - ⇒ The display shows an explanation of the error code and several details of the boiler when the error occurred.
10. To clear the error memory, press and hold the  button.

Fig.93 Installer level



AD-3001378-02

Fig.94 Error details

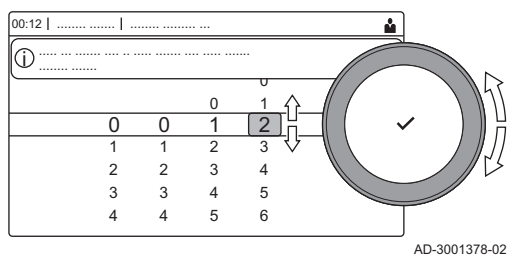
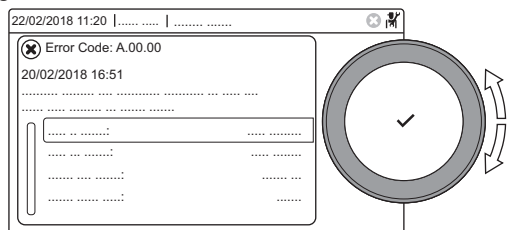

AD-3001381-01

11 User instructions

11.1 Start-up

Start up the boiler as follows:

1. Open the boiler gas tap.
2. Insert the boiler plug into an earthed socket.
3. Check the water pressure of the system. If necessary, top up the system.

The current operating condition of the boiler is shown on the display.

11.2 Accessing the user level menus

The tiles on the home screen provide quick access for the user to the corresponding menus.

Fig.95 Menu selection

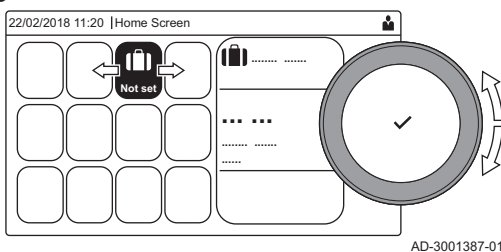

1. Use the rotary knob to select the required menu.

Fig.96 Confirm menu selection

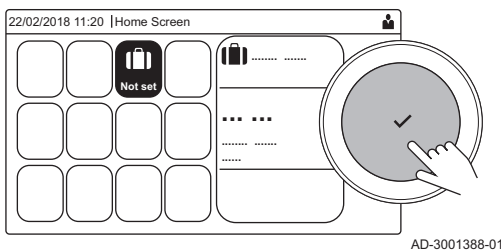

2. Press the ✓ button to confirm the selection.
 - ⇒ The available settings of this selected menu appear in the display.
3. Use the rotary knob to select the desired setting.
4. Press the ✓ button to confirm the selection.
 - ⇒ All options for change will appear in the display (if a setting cannot be changed, **Cannot edit read-only datapoint** will appear in the display).
5. Use the rotary knob to change the setting.
6. Press the ✓ button to confirm the selection.
7. Use the rotary knob to select the next setting or press the ↻ button to return to the home screen.

11.3 Heating circuit configuration

For every heating circuit there is a quick user settings menu available. Select the heating circuit you want to configure by selecting the tile [🏠], [🔧], [🕒], [🌡️], [📅], [🌧️] or [⚙️]





Tab.72 Menu to configure a heating circuit

Icon	Menu	Function
🕒	Scheduling	Set the scheduling mode and choose a timer program already created
🔧	Manual	Set the manual mode; the room temperature setpoint is set to a fixed setting
🌡️	Short temperature change	Set the temporary mode; the room temperature setpoint is changed temporarily
📅	Holiday	Set the start and end date of your holiday to lower the room temperature setpoint.
🌧️	Antifrost	Set the frost protection mode; the minimum room temperature protects your system from freezing
🕒	Set Heating Activity Temperatures	Set the room temperature setpoint for each activity of the timer program. See: Timer program to control the room temperature, page 85
⚙️	Zone configuration	Access the settings for the configuration of the heating circuit.

Tab.73 Extended menu to configure a heating circuit  **Zone configuration**

Menu	Function
Short temperature change	Change the room temperature temporarily, if required
OperatingZoneMode	Select the heating operating mode: Scheduling, Manual or Antifrost
Manu ZoneRoomTempSet	Set the room temperature manually to a fixed setting
Heating Schedule	Create a timer program (up to 3 programs allowed). See: Creating a timer program, page 85
Set Heating Activity Temperatures	Set the room temperature for each activity of the timer program
ZoneTimeProg Select	Select a timer program (3 options)
Holiday Mode	Set the start and end date of your holiday and the reduced temperature for this zone
Zone friendly Name	Create or change the name of the heating circuit
Icon display zone	Select the icon of the heating circuit
OperatingZoneMode	Read the current operating mode of the heating circuit

11.4 Changing the display settings

1. Press the  button.
2. Press the  button to confirm the selection.
3. Use the rotary knob to select **System Settings** .
4. Press the  button to confirm the selection.
5. Perform one of the operations described in the table below:

Tab.74 Display settings

System Settings menu	Settings
Set Date and Time	Set the current date and time
Select Country and Language	Select your country and language
Daylight Saving Time	Enable or disable daylight saving time
Installer Details	Read out the name and phone number of the installer
Set Heating Activity Names	Create the names for the activities of the timer program
Set Screen Brightness	Adjust the brightness of the screen
Set click sound	Enable or disable the click sound of the rotary knob
License Information	Read out detailed license information from the device platform application

11.5 Timer program to control the room temperature





11.5.1 Creating a timer program

A timer program allows you to vary the room temperature per hour and per day. The room temperature is linked to the activity of the timer program.



Important

You can create up to three timer programs per zone. For example, you can create a program for a week with normal working hours and a programme for a week when you are at home most of the time.

1. Select the tile of the zone you want to change.
2. Press the  button to confirm the selection.
3. Use the rotary knob to select  **Zone configuration**.
4. Press the  button to confirm the selection.
5. Use the rotary knob to select **Heating Schedule**.
6. Press the  button to confirm the selection.
7. Use the rotary knob to select the timer program you want to modify: **Schedule 1**, **Schedule 2** or **Schedule 3**.

8. Press the ✓ button to confirm the selection.
 - ⇒ Activities scheduled for Monday are displayed. The last scheduled activity of a day is active until the first activity of the next day. At initial start-up, all weekdays have two standard activities; **Home** starting at 6:00 and **Sleep** starting at 22:00.
9. Use the rotary knob to select the weekday you want to modify.

Fig.97 Weekday

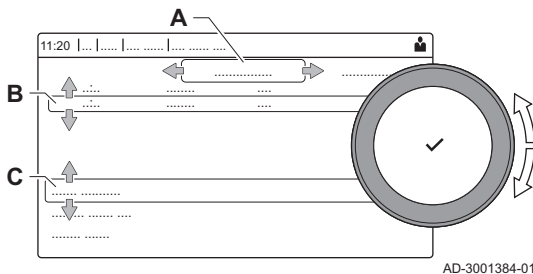

- A Weekday
- B Overview of scheduled activities
- C List of actions

10. Perform the following actions, if necessary:
 - 10.1. **Edit** the start time and/or activity of a scheduled activity.
 - 10.2. **Add** a new activity.
 - 10.3. **Delete** a scheduled activity (select the activity **Delete**).
 - 10.4. **Copy** the scheduled activities of the weekday to other days.
 - 10.5. **Change the temperature** linked to an activity.

11.6 Reading the installer's name and phone number

The installer can set his name and phone number in the control panel. You can read this information when you want to contact the installer.

1. Press the ≡ button.
2. Press the ✓ button to confirm the selection.
3. Select **System Settings** ⚙️
4. Press the ✓ button to confirm the selection.
5. Select **Installer Details**
6. Press the ✓ button to confirm the selection.
 - ⇒ The installer's name and phone number is shown.

11.7 Shut-down

Shut-down the boiler as follows:

1. Turn off the boiler using the on/off switch.
2. Shut off the gas supply.
3. Keep the installation frost-free.
 - Do not shut-down the boiler if the installation can't be kept frost-free.

11.8 Frost protection



Caution

- Drain the boiler and central heating system if you are not going to use your home or the building for a long time and there is a chance of frost.
- The frost protection does not work if the boiler is out of operation.
- The built-in boiler protection is only activated for the boiler and not for the system and radiators.
- Open the valves of all the radiators connected to the system.

Set the temperature control low, for example to 10°C.

If the temperature of the central heating water in the boiler drops too low, the built-in boiler protection system is activated. This system works as follows:

- If the water temperature is lower than 7°C, the pump switches on.
- If the water temperature is lower than 4°C, the boiler switches on.
- If the water temperature is higher than 10°C, the burner shuts down and the pump continues to run for a short time.

To prevent the system and radiators freezing in frost-sensitive areas (e.g. a garage), a frost thermostat or, if feasible, an outdoor sensor can be connected to the boiler.

11.9 Cleaning the casing

1. Clean the outside of the appliance using a damp cloth and a mild detergent.

12 Technical specifications

12.1 Homologations

12.1.1 Certifications

Tab.75 Certifications

CE identification number	PIN 0063CU3937
Class NOx ⁽¹⁾	6
Type of flue gas connection	B ₂₃ , B _{23P} ⁽²⁾ C ₃₃ , C ₅₃ , C ₆₃ , C ₉₃
(1) EN 15502-1 (2) When installing a boiler with connection type B ₂₃ , B _{23P} , the IP rating of the boiler is lowered to IP20.	

■ Unit categories

Tab.76 Unit categories

Country	Category	Gas type	Connection pressure (mbar)
United Kingdom	I _{2H}	G20 (H gas)	20

■ BREEAM compliance

The Gas 320/620 Ace complies with the BREEAM emission requirements. In order to meet these requirements, some boiler parameter values need to be changed.



Important

Refer to the chapter for the boiler's BREEAM settings.



For more information, see

Fan speeds for BREEAM compliance, page 50

12.1.2 Directives

In addition to the legal requirements and guidelines, the supplementary guidelines in this manual must also be followed.

Supplements or subsequent regulations and guidelines that are valid at the time of installation shall apply to all regulations and guidelines specified in this manual.

12.1.3 Bluetooth® wireless technology

This product is equipped with Bluetooth wireless technology.

The Bluetooth® word mark and logos are registered trademarks owned by Bluetooth SIG, Inc. and any use of such marks by BDR Thermea Group is under license. Other trademarks and trade names are those of their respective owners.

Fig.98 Logo



AD-3001854-01

12.1.4 Factory test

Before leaving the factory, each boiler is optimally set and tested for:

- Electrical safety.
- Adjustment of O₂/CO₂.
- Water tightness.

- Gas tightness.
- Parameter setting.

12.2 Electrical diagram

Fig.99 Electrical diagram

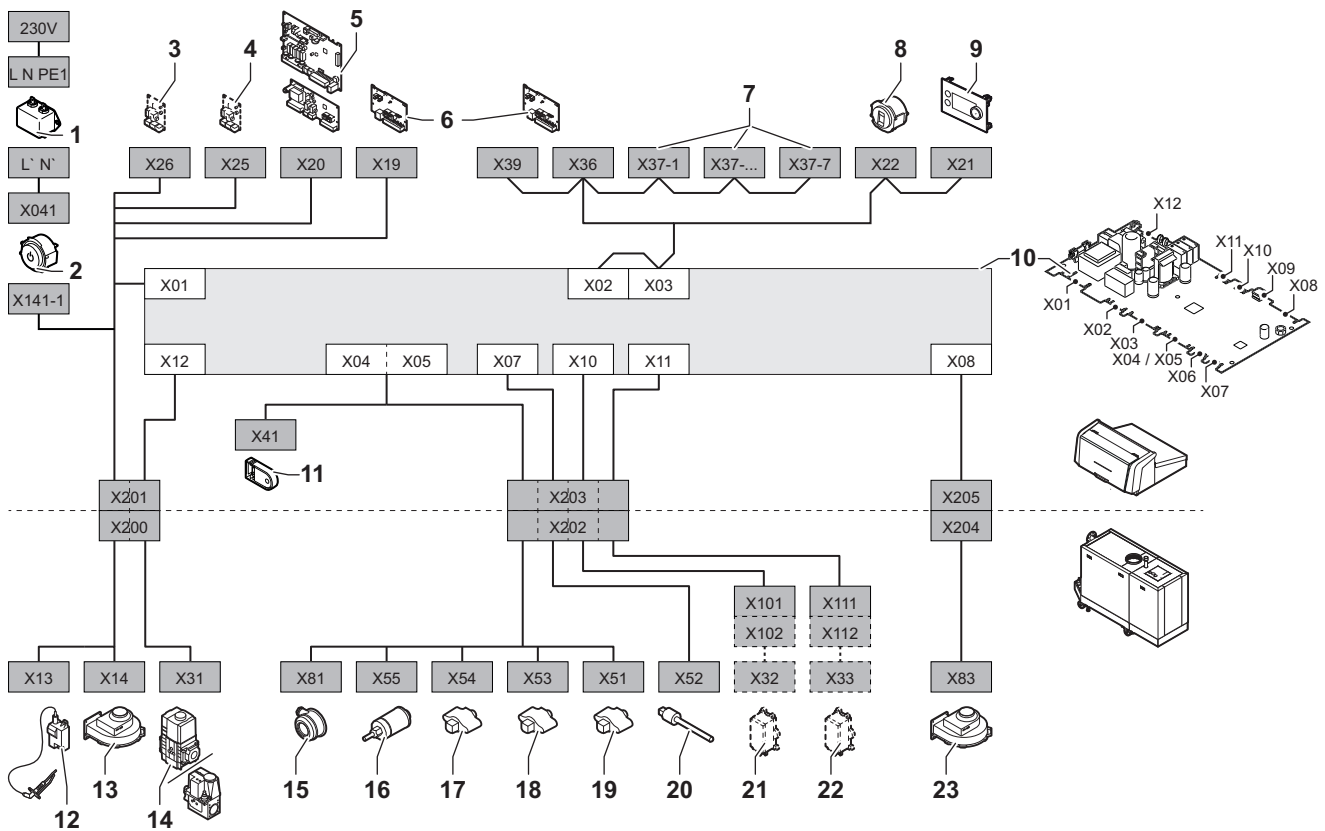

AD-3001548-03

- | | |
|---|--------------------------------------|
| 1 Line filter | 12 Ignition transformer power supply |
| 2 On / off switch | 13 Fan power supply |
| 3 SCB expansion board power supply | 14 Gas control valve |
| 4 SCB expansion board power supply | 15 Air pressure differential switch |
| 5 SCB zone expansion board power supply | 16 Water pressure sensor |
| 6 CB-01 connection board power supply (X19) and CAN connections (X36 and X39) | 17 Return temperature sensor |
| 7 SCB expansion board CAN connections (X37-1 - X37-7) | 18 Heat exchanger temperature sensor |
| 8 Service connector | 19 Flow temperature sensor |
| 9 Control panel (HMI) | 20 Flue gas temperature sensor |
| 10 Control unit CU-GH13 | 21 Valve proving system (VPS) |
| 11 Configuration storage unit (CSU) | 22 Gas pressure switch (GPS) |
| | 23 Fan PWM signal |

12.3 Dimensions and connections Gas 320 Ace

Fig.100 Dimensions Gas 320 Ace

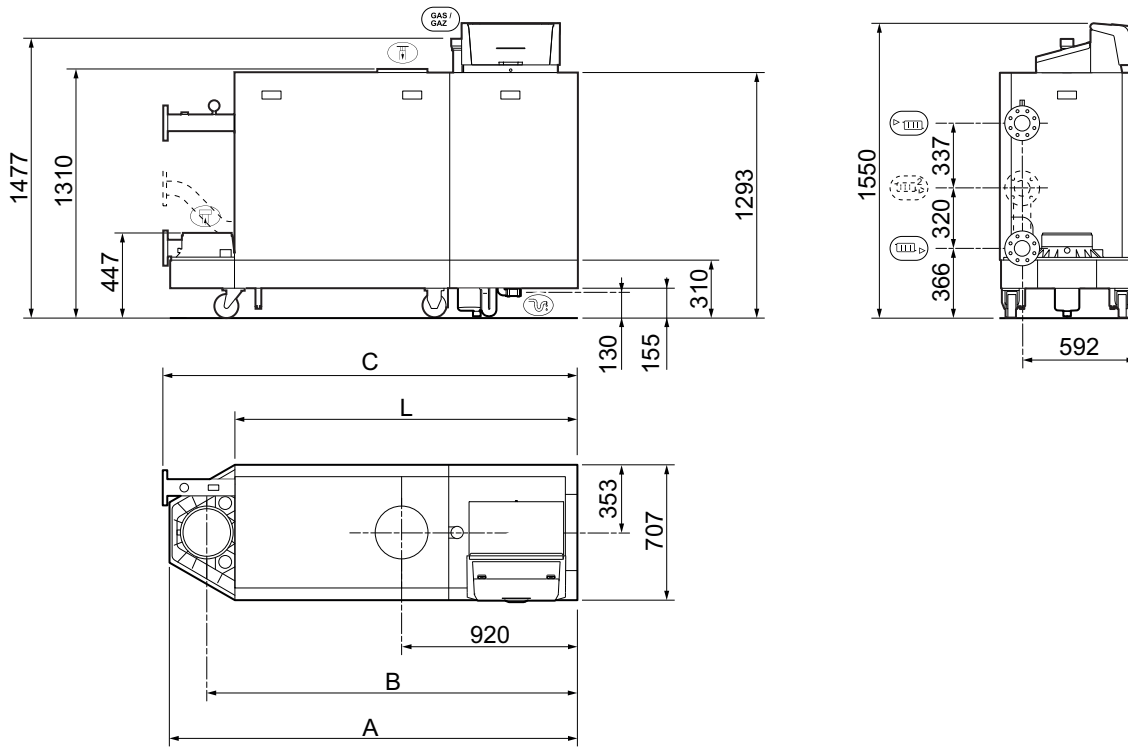

AD-3001442-02

	Gas 320 Ace	285 355 430	500 575 650
A	Base length	1833 mm	2142 mm
B	Flue gas outlet centre dimension	1635 mm	1944 mm
C	Total length	1862 mm	2172 mm
L	Casing length	1490 mm	1800 mm
(1)	Central heating circuit flow	Flange DN 80 PN10	Flange DN 80 PN10
(1)	Central heating circuit return	Flange DN 80 PN10 ⁽¹⁾	Flange DN 80 PN10 ⁽¹⁾
	Gas connection	G2"	G2"
	Condensation outlet	Ø 32 mm (internal)	Ø 32 mm (internal)
	Flue gas outlet	Ø 250 mm	Ø 250 mm
	Air supply	Ø 250 mm	Ø 250 mm
(2)	Second return (optional)	Flange DN 65 PN10	Flange DN 65 PN10

(1) The inner bore of the return flange is DN65.

12.4 Dimensions and connections Gas 620 Ace

Fig.101 Dimensions Gas 620 Ace

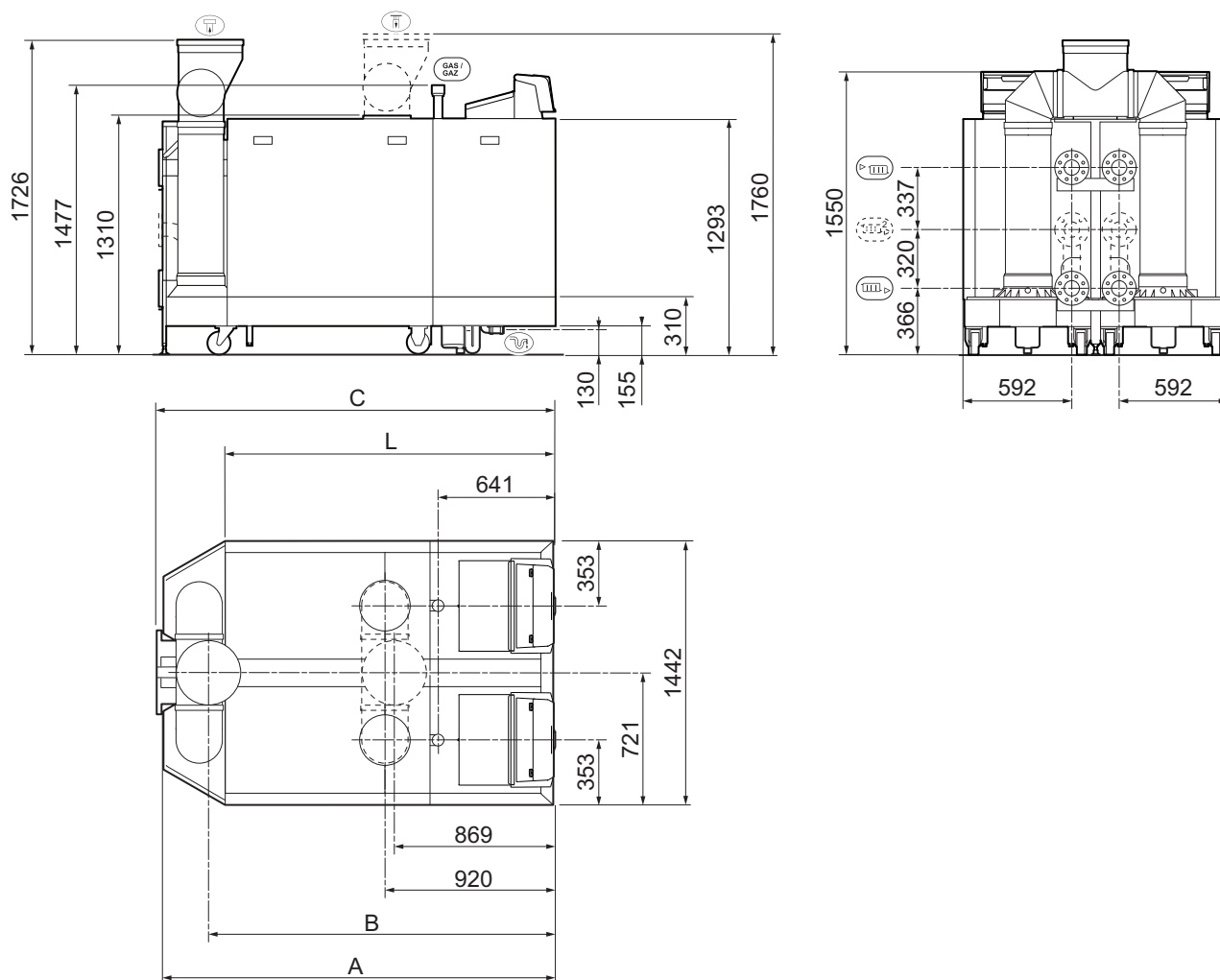

AD-3001443-02

	Gas 620 Ace	570 710 860	1000 1150 1300
A	Base length	1833 mm	2142 mm
B	Flue gas outlet centre dimension	1582 mm	1892 mm
C	Total length	1862 mm	2172 mm
L	Casing length	1490 mm	1800 mm
▶ (III)	Central heating circuit flow	Flange DN 80 PN10	Flange DN 80 PN10
(III) ▶	Central heating circuit return	Flange DN 80 PN10 ⁽¹⁾	Flange DN 80 PN10 ⁽¹⁾
GAS/ GAZ	Gas connection	G2"	G2"
🌀	Condensation outlet	Ø 32 mm (internal)	Ø 32 mm (internal)
⌋	Flue gas outlet	Ø 350 mm	Ø 350 mm
⌋	Air supply Air supply manifold (optional)	Ø 250 mm Ø 350 mm	Ø 250 mm Ø 350 mm
(III) ↗	Second return (optional)	Flange DN 65 PN10	Flange DN 65 PN10

(1) The inner bore of the return flange is DN65.

12.5 Hydraulic resistance

Tab.77 Hydraulic resistance

Heat exchanger size	Hydraulic resistance in mbar										
	ΔT 10 °C	ΔT 11 °C	ΔT 12 °C	ΔT 13 °C	ΔT 14 °C	ΔT 15 °C	ΔT 16 °C	ΔT 17 °C	ΔT 18 °C	ΔT 19 °C	ΔT 20 °C
5 sections: Gas 320 Ace 285 Gas 620 Ace 570	452	374	314	267	231	201	177	156	140	125	113
6 sections: Gas 320 Ace 355 Gas 620 Ace 710	440	364	306	260	224	196	172	152	136	122	110
7 sections: Gas 320 Ace 430 Gas 620 Ace 860	480	397	333	284	245	213	188	166	148	133	120
8 sections: Gas 320 Ace 500 Gas 620 Ace 1000	440	364	306	260	224	196	172	152	136	122	110
9 sections: Gas 320 Ace 575 Gas 620 Ace 1150	500	413	347	296	255	222	195	173	154	139	125
10 sections: Gas 320 Ace 650 Gas 620 Ace 1300	520	430	361	308	265	231	203	180	160	144	130

12.6 Gas 320 Ace technical data

Tab.78 General

Gas 320 Ace				285	355	430	500	575	650
Number of sections				5	6	7	8	9	10
Nominal output	P_n 80/60 °C	kW	min max ⁽¹⁾	51.1 260.7	64.8 326.7	78.6 394.8	91.5 461.0	105.5 530.4	118.7 600.9
Nominal output	P_{nc} 70/50 °C	kW	max ⁽¹⁾	262.0	328.0	396.4	462.4	532.0	602.1
Nominal output	P_{nc} 50/30 °C	kW	max ⁽¹⁾	278.8	350.3	424.5	497.1	573.5	651.5
Nominal input	Q_{nh} (H_i)	kW	min max ⁽¹⁾	54 266	68 333	82 402	95 469	109 539	122 610
Nominal input	Q_{nh} (H_s)	kW	min max ⁽¹⁾	60 295.6	75.6 370.0	91.1 446.7	105.6 521.1	121.1 598.9	135.6 677.8
Full load central heating efficiency	P_n (H_i) 80/60 °C	%		98.0	98.1	98.2	98.3	98.4	98.5
Full load central heating efficiency	P_n (H_i) 70/50 °C	%		98.5	98.5	98.6	98.6	98.7	98.7
Full load central heating efficiency	H_i 50/30 °C	%		104.8	105.2	105.6	106.0	106.4	106.8
Min load central heating efficiency	H_i Return temperature 60 °C	%		94.7	95.3	95.8	96.3	96.8	97.3
Part load central heating efficiency	P_n (H_i) Return temperature 30 °C	%		109.2	109.0	108.8	108.6	108.3	108.1
Full load central heating efficiency	P_n (H_s) 80/60 °C	%		88.3	88.4	88.5	88.6	88.6	88.7
Full load central heating efficiency	P_n (H_s) 70/50 °C	%		88.7	88.7	88.8	88.8	88.9	88.9
Full load central heating efficiency	H_s 50/30 °C	%		94.4	94.8	95.1	95.5	95.9	96.2

Gas 320 Ace				285	355	430	500	575	650
Min load central heating efficiency	H_s Return temperature 60 °C	%		85.3	85.9	86.3	86.8	87.2	87.7
Part load central heating efficiency	$P_n (H_s)$ Return temperature 30 °C	%		98.4	98.2	98.0	97.8	97.6	97.4
(1)  Factory setting									

Tab.79 Gas and flue gas data

Gas 320 Ace				285	355	430	500	575	650
Gas inlet pressure	G20	mbar	min max	17 25	17 25	17 25	17 25	17 25	17 25
Gas consumption	G20	m ³ /h	min max	5.7 28.1	7.2 35.2	8.7 42.5	10.1 49.6	11.5 57.0	12.9 64.6
NOx annual emissions	G20 O ₂ = 0% (EN15502)	ppm		29	29	30	30	30	31
NOx annual emissions	G20 H_i (EN15502)	mg/kWh		47	48	49	50	51	52
NOx annual emissions	G20 H_s (EN15502)	mg/kWh		43	43	44	45	46	47
NOx annual emissions	BREEAM H_s	mg/kWh		15	16	16	17	18	18
	BREEAM	Credits		2	2	2	2	2	2
Flue gas amount		kg/h	min max	91 448	115 561	138 677	160 790	184 907	205 1027
Flue gas temperature		°C	min max	30 60	30 61	30 64	30 63	30 66	30 65
Maximum counter pressure for flue gas outlet		Pa		130	120	130	150	150	150
Flue efficiency	(H_i) 80/60 °C Ambient temperature 20 °C	%		97.8	97.8	97.8	97.7	97.7	97.7
Flue losses	(H_i) 80/60 °C Ambient temperature 20 °C	%		2.2	2.2	2.2	2.3	2.3	2.3

Tab.80 Central heating circuit data

Gas 320 Ace				285	355	430	500	575	650
Water content		l		49	60	71	82	93	104
Water operating pressure		bar	min	0.8	0.8	0.8	0.8	0.8	0.8
Water operating pressure	<i>PMS</i>	bar	max	7.0	7.0	7.0	7.0	7.0	7.0
Water temperature		°C	max	110	110	110	110	110	110
Operating temperature		°C	max	90	90	90	90	90	90
Water flow	$\Delta T=11K$	m ³ /h	max	20.4	25.6	30.9	36.1	41.5	47.0
Water flow at full load central heating	80/60 °C	m ³ /h	nom	11.1	13.9	16.8	19.6	22.5	22.5
Water flow at full load central heating	70/50 °C	m ³ /h	nom	11.3	14.1	17.1	19.9	22.9	25.9
Water flow at full load central heating	50/30 °C	m ³ /h	nom	12.0	15.1	18.3	21.4	24.7	28.1
Water flow at minimum load central heating	50/30 °C	m ³ /h	nom	2.5	3.2	3.8	4.4	5.1	5.7
Water flow at minimum load central heating	70/30 °C	m ³ /h	nom	1.3	1.6	1.9	2.2	2.5	2.8
Water side pressure drop	$\Delta T=40K$	mbar		34	33	36	33	38	39
Water side pressure drop	$\Delta T=30K$	mbar		60	59	64	59	67	69

Gas 320 Ace				285	355	430	500	575	650
Water side pressure drop	$\Delta T=20K$	mbar		113	110	120	110	125	130
Water side pressure drop	$\Delta T=11K$	mbar		374	364	397	364	413	435
Standby loss	With heat exchanger insulation kit	W %	($\Delta T = 30K$) ⁽¹⁾	464	479	493	508	522	537
(1) $\Delta T =$ (boiler temperature – ambient temperature).									

Tab.81 Electrical data

Gas 320 Ace				285	355	430	500	575	650
Supply voltage		V~/Hz		230/50	230/50	230/50	230/50	230/50	230/50
Power consumption ⁽¹⁾	Max input CH	W	max	280	345	450	576	768	720
Power consumption ⁽¹⁾	Max input CH (<i>elmax</i>)	W	max	280	345	450	576	768	720
Power consumption ⁽¹⁾	Min input CH	W	min	52	57	64	72	68	60
Power consumption ⁽¹⁾	Min input CH (<i>elmin</i>)	W	min	60	62	76	86	89	80
Power consumption ⁽¹⁾	standby (<i>P_{SB}</i>)	W	min	10	9	10	10	10	10
Electrical protection index ⁽²⁾		IP		X1	X1	X1	X1	X1	X1
Fuse – main (power connector)		(AT)		10	10	10	10	10	10
Fuse – CU-GH13		(AT)		1.6	1.6	1.6	1.6	1.6	1.6
Fuse – CB-01		(AT)		6.3	6.3	6.3	6.3	6.3	6.3
(1) Without pump (2) For a room-sealed system.									

Tab.82 Other data

Gas 320 Ace				285	355	430	500	575	650
Total weight with packaging	Including control box	kg		436	470	505	572	608	645
Total weight without packaging	Including control box	kg		366	400	435	497	533	570
Weight of the split boiler	Heat exchanger side	kg		249	283	317	356	390	424
Average acoustic level at a distance of 1 metre from the boiler ⁽¹⁾	LpA	dB(A)		61.2	61.2	64.8	64.8	64.8	64.8
Average acoustic level ⁽²⁾	LwA	dB(A)		77.6	77.6	81.2	81.4	81.4	81.4
Ambient temperature		°C	max	40	40	40	40	40	40
(1) For a sealed installation (2) For a sealed installation									

Tab.83 Technical parameters

Gas 320 Ace				285	355	430	500	575	650
Condensing boiler				Yes	Yes	Yes	Yes	Yes	Yes
Low-temperature boiler ⁽¹⁾				No	No	No	No	No	No
B1 boiler				No	No	No	No	No	No
Cogeneration space heater				No	No	No	No	No	No
Combination heater				No	No	No	No	No	No
Rated heat output	<i>Prated</i>	kW		261	327	395	461	530	601
Useful heat output at nominal heat output and high temperature operation ⁽²⁾	<i>P₄</i>	kW		260.7	326.7	394.8	461.0	530.4	600.9
Useful heat output at 30% of rated heat output and low temperature regime ⁽¹⁾	<i>P₁</i>	kW		87.1	108.9	131.2	152.8	175.1	197.8

Gas 320 Ace			285	355	430	500	575	650
Seasonal space heating energy efficiency	η_s	%	-	-	-	-	-	-
Useful efficiency at rated heat output and high temperature regime ⁽²⁾	η_4	%	88.3	88.4	88.5	88.6	88.7	88.7
Useful efficiency at 30% of rated heat output and low temperature regime ⁽¹⁾	η_1	%	98.4	98.2	98.0	97.8	97.6	97.4
Auxiliary electricity consumption								
Full load	el_{max}	kW	0.280	0.345	0.450	0.576	0.768	0.720
Part load	el_{min}	kW	0.060	0.062	0.076	0.086	0.089	0.080
Standby mode	P_{SB}	kW	0.010	0.009	0.010	0.010	0.010	0.010
Other items								
Standby heat loss	P_{stby}	kW	-	-	-	-	-	-
Ignition burner power consumption	P_{ign}	kW	-	-	-	-	-	-
Annual energy consumption	Q_{HE}	kWh GJ	-	-	-	-	-	-
Sound power level, indoors	L_{WA}	dB	78	78	81	81	81	81
Emissions of nitrogen oxides	NO _x	mg/kWh	43	43	44	45	46	47
(1) Low temperature means 30 °C for condensing boilers, 37 °C for low temperature boilers and 50 °C (at heater inlet) for other heating appliances.								
(2) High temperature operation means 60 °C return temperature at heater inlet and 80 °C feed temperature at heater outlet.								

**See**

Refer to the back cover for contact details.

12.7 Gas 620 Ace technical data

Tab.84 General

Gas 620 Ace				570	710	860	1000	1150	1300
Number of sections				2x5	2x6	2x7	2x8	2x9	2x10
Nominal output	P_n 80/60 °C	kW	min max ⁽¹⁾	75.8 521.4	86.7 653.3	122.6 789.5	122.3 922.1	148.1 1060.8	165.4 1201.7
Nominal output	P_{nc} 70/50 °C	kW	max ⁽¹⁾	524.0	656.3	792.7	924.9	1064.0	1204.1
Nominal output	P_{nc} 50/30 °C	kW	max ⁽¹⁾	557.5	700.6	849.0	994.3	1147.0	1303.0
Nominal input	$Q_{nh}(H_i)$	kW	min max ⁽¹⁾	80 532	91 666	128 804	127 938	153 1078	170 1220
Nominal input	$Q_{nh}(H_s)$	kW	min max ⁽¹⁾	88.9 591.1	101.1 740.0	142.2 893.3	141.1 1042.2	170.0 1197.8	188.9 1355.6
Full load central heating efficiency	$P_n(H_i)$ 80/60 °C	%		98.0	98.1	98.2	98.3	98.4	98.5
Full load central heating efficiency	$P_n(H_i)$ 70/50 °C	%		98.5	98.5	98.6	98.6	98.7	98.7
Full load central heating efficiency	H_i 50/30 °C	%		104.8	105.2	105.6	106.0	106.4	106.8
Min load central heating efficiency	H_i Return temperature 60 °C	%		94.7	95.3	95.8	96.3	96.8	97.3
Part load central heating efficiency	$P_n(H_i)$ Return temperature 30 °C	%		109.2	109.0	108.8	108.6	108.3	108.1
Full load central heating efficiency	$P_n(H_s)$ 80/60 °C	%		88.3	88.4	88.5	88.6	88.6	88.7
Full load central heating efficiency	$P_n(H_s)$ 70/50 °C	%		88.7	88.7	88.8	88.8	88.9	88.9
Full load central heating efficiency	H_s 50/30 °C	%		94.4	94.8	95.1	95.5	95.9	96.2

Gas 620 Ace				570	710	860	1000	1150	1300
Min load central heating efficiency	H_s Return temperature 60 °C	%		85.3	85.9	86.3	86.8	87.2	87.7
Part load central heating efficiency	$P_n (H_s)$ Return temperature 30 °C	%		98.4	98.2	98.0	97.8	97.6	97.4
(1)  Factory setting									

Tab.85 Gas and flue gas data

Gas 620 Ace				570	710	860	1000	1150	1300
Gas inlet pressure	G20	mbar	min max	17 25	17 25	17 25	17 25	17 25	17 25
Gas consumption	G20	m ³ /h	min max	8.5 56.3	9.6 70.5	13.5 85.1	13.4 99.3	16.2 114.1	18.0 129.1
NOx annual emissions	G20 O ₂ = 0% (EN15502)	ppm		29	29	30	30	30	31
NOx annual emissions	G20 H_i (EN15502)	mg/kWh		47	48	49	50	51	52
NOx annual emissions	G20 H_s (EN15502)	mg/kWh		43	43	44	45	46	47
NOx annual emissions	BREEAM H_s	mg/kWh		15	16	16	17	18	18
	BREEAM	Credits		2	2	2	2	2	2
Flue gas amount		kg/h	min max	135 896	153 1121	216 1354	214 1579	258 1815	286 2054
Flue gas temperature		°C	min max	30 60	30 61	30 64	30 63	30 66	30 65
Maximum counter pressure for flue gas outlet		Pa		130	120	130	150	150	150
Flue efficiency	(H_i) 80/60 °C Ambient temperature 20 °C	%		97.8	97.8	97.8	97.7	97.7	97.7
Flue losses	(H_i) 80/60 °C Ambient temperature 20 °C	%		2.2	2.2	2.2	2.3	2.3	2.3

Tab.86 Central heating circuit data

Gas 620 Ace				570	710	860	1000	1150	1300
Water content		l		98	120	142	164	186	208
Water operating pressure		bar	min	0.8	0.8	0.8	0.8	0.8	0.8
Water operating pressure	<i>PMS</i>	bar	max	7.0	7.0	7.0	7.0	7.0	7.0
Water temperature		°C	max	110	110	110	110	110	110
Operating temperature		°C	max	90	90	90	90	90	90
Water flow	$\Delta T=11K$	m ³ /h	max	40.8	51.2	61.8	72.2	83.1	94.1
Water flow at full load central heating	80/60 °C	m ³ /h	nom	22.2	27.8	33.6	39.2	45.1	51.0
Water flow at full load central heating	70/50 °C	m ³ /h	nom	22.6	28.3	34.1	39.8	45.8	51.9
Water flow at full load central heating	50/30 °C	m ³ /h	nom	24.0	30.2	36.6	42.8	49.4	56.1
Water flow at minimum load central heating	50/30 °C	m ³ /h	nom	3.7	4.3	6.0	5.9	7.1	7.9
Water flow at minimum load central heating	70/30 °C	m ³ /h	nom	1.9	2.1	3.0	3.0	3.6	4.0
Water side pressure drop	$\Delta T=40K$, per heat exchanger	mbar		34	33	36	33	38	39

Gas 620 Ace				570	710	860	1000	1150	1300
Water side pressure drop	$\Delta T=30K$, per heat exchanger	mbar		60	59	64	59	67	69
Water side pressure drop	$\Delta T=20K$, per heat exchanger	mbar		113	110	120	110	125	130
Water side pressure drop	$\Delta T=11K$, per heat exchanger	mbar		374	364	397	364	413	435
Standby loss	With heat exchanger insulation kit	W	($\Delta T = 30K$) ⁽¹⁾	928	958	986	1016	1044	1074

(1) ΔT = (boiler temperature – ambient temperature).

Tab.87 Electrical data

Gas 620 Ace				570	710	860	1000	1150	1300
Supply voltage		V~/Hz		230/50	230/50	230/50	230/50	230/50	230/50
Power consumption ⁽¹⁾	Max input CH	W	max	560	690	900	1152	1536	1440
Power consumption ⁽¹⁾	Max input CH (<i>elmax</i>)	W	max	560	690	900	1152	1536	1440
Power consumption ⁽¹⁾	Min input CH	W	min	120	124	160	166	178	148
Power consumption ⁽¹⁾	Min input CH (<i>elmin</i>)	W	min	120	124	152	172	178	160
Power consumption ⁽¹⁾	standby (<i>P_{SB}</i>)	W	min	20	18	20	20	20	20
Electrical protection index ⁽²⁾		IP		X1	X1	X1	X1	X1	X1
Fuse – main (power connector)		(AT)		10	10	10	10	10	10
Fuse – CU-GH13		(AT)		1.6	1.6	1.6	1.6	1.6	1.6
Fuse – CB-01		(AT)		6.3	6.3	6.3	6.3	6.3	6.3

(1) Without pump
(2) For a room-sealed system.

Tab.88 Other data

Gas 620 Ace				570	710	860	1000	1150	1300
Total weight with packaging	Including control box	kg		851	915	981	1111	1179	1249
Total weight without packaging	Including control box	kg		711	775	841	961	1029	1099
Weight of the split boiler	Heat exchanger side	kg		249	283	317	356	390	424
Average acoustic level at a distance of 1 metre from the boiler ⁽¹⁾	LpA	dB(A)		64.2	64.2	67.8	67.8	67.8	67.8
Average acoustic level ⁽²⁾	LwA	dB(A)		81.2	81.2	84.8	85.0	85.0	85.0
Ambient temperature		°C	max	40	40	40	40	40	40

(1) For a sealed installation
(2) For a sealed installation

Tab.89 Technical parameters

Gas 620 Ace				570	710	860	1000	1150	1300
Condensing boiler				Yes	Yes	Yes	Yes	Yes	Yes
Low-temperature boiler ⁽¹⁾				No	No	No	No	No	No
B1 boiler				No	No	No	No	No	No
Cogeneration space heater				No	No	No	No	No	No
Combination heater				No	No	No	No	No	No
Rated heat output	<i>Prated</i>	kW		521	653	790	922	1061	1202

Gas 620 Ace			570	710	860	1000	1150	1300
Useful heat output at nominal heat output and high temperature operation ⁽²⁾	P_4	kW	521.4	653.3	789.5	922.1	1060.8	1201.7
Useful heat output at 30% of rated heat output and low temperature regime ⁽¹⁾	P_1	kW	174.3	217.8	262.4	305.6	350.3	395.6
Seasonal space heating energy efficiency	η_s	%	-	-	-	-	-	-
Useful efficiency at rated heat output and high temperature regime ⁽²⁾	η_4	%	88.3	88.4	88.5	88.6	88.7	88.7
Useful efficiency at 30% of rated heat output and low temperature regime ⁽¹⁾	η_1	%	98.4	98.2	98.0	97.8	97.6	97.4
Auxiliary electricity consumption								
Full load	el_{max}	kW	0.560	0.690	0.900	1.152	1.536	1.440
Part load	el_{min}	kW	0.120	0.124	0.152	0.172	0.178	0.160
Standby mode	P_{SB}	kW	0.020	0.018	0.020	0.020	0.020	0.020
Other items								
Standby heat loss	P_{stby}	kW	-	-	-	-	-	-
Ignition burner power consumption	P_{ign}	kW	-	-	-	-	-	-
Annual energy consumption	Q_{HE}	kWh GJ	-	-	-	-	-	-
Sound power level, indoors	L_{WA}	dB	81	81	85	85	85	85
Emissions of nitrogen oxides	NO_X	mg/kWh	43	43	44	45	46	47
(1) Low temperature means 30 °C for condensing boilers, 37 °C for low temperature boilers and 50 °C (at heater inlet) for other heating appliances.								
(2) High temperature operation means 60 °C return temperature at heater inlet and 80 °C feed temperature at heater outlet.								

**See**

Refer to the back cover for contact details.

12.8 BLE Smart Antenna technical data

Tab.90 Technical data

Bluetooth frequency band	2400 – 2483.5 MHz
Bluetooth power	+5 dBm

13 Appendix

13.1 ErP information

13.1.1 Product fiche

Tab.91 Product fiche

Remeha - Gas 320 Ace		285	355	430	500	575	650
Seasonal space heating energy efficiency class		-	-	-	-	-	-
Rated heat output (<i>Prated or Psup</i>)	kW	261	327	395	461	530	601
Seasonal space heating energy efficiency	%	-	-	-	-	-	-
Annual energy consumption	GJ	-	-	-	-	-	-
Sound power level L_{WA} indoors	dB	78	78	81	81	81	81

Tab.92 Product fiche

Remeha - Gas 620 Ace		570	710	860	1000	1150	1300
Seasonal space heating energy efficiency class		-	-	-	-	-	-
Rated heat output (<i>Prated or Psup</i>)	kW	521	653	790	922	1061	1202
Seasonal space heating energy efficiency	%	-	-	-	-	-	-
Annual energy consumption	GJ	-	-	-	-	-	-
Sound power level L_{WA} indoors	dB	81	81	85	85	85	85



See

For specific precautions in relation to assembly, installation and maintenance: Safety, page 6

13.2 EC declaration of conformity

The appliance complies with the standard type described in the EC declaration of conformity. It has been manufactured and commissioned in accordance with European directives.

The original declaration of conformity is available from the manufacturer.

13.2.1 Declaration of conformity for wireless devices

All wireless communication devices comply with the standard type described in the EC declaration of conformity. They have been manufactured and commissioned in accordance with European directives.



See

The website for the full declaration of conformity: <https://declaration-of-conformity.bdrthermeagroup.com>

Fig.102 QR code



AD-3001616-01

Original instructions - © Copyright

All technical and technological information contained in these technical instructions, as well as any drawings and technical descriptions supplied, remain our property and shall not be multiplied without our prior consent in writing. Subject to alterations.

T +44 (0)118 978 3434
F +44 (0)118 978 6977
E boilers@remeha.co.uk

Remeha Commercial UK
Innovations House
3 Oaklands Business Centre
Oaklands Park
RG41 2FD Wokingham

